

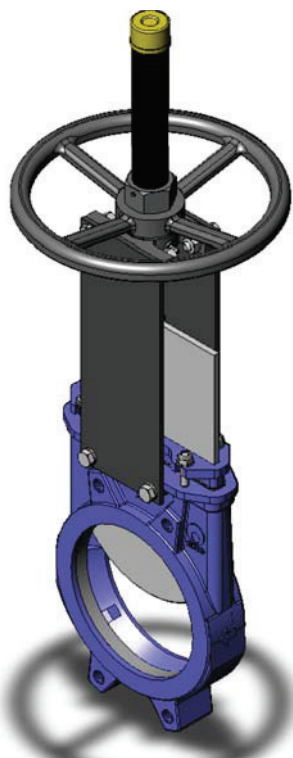

KNIFE GATE VALVES AND CHECK VALVES



PRODUCT DESCRIPTION

Wafer style, uni-directional knife gate valve. One piece integral cast body with guides to support the gate and seating wedges. High flow rates with low pressure drops. Several seat and packing materials available. Face to face dimension according CMO standard. Arrow in the body pointing the flow direction.

GENERAL APPLICATIONS

This knife gate valve is appropriate for liquids with a solids concentration of maximum 5%. If it is used for dry solids in gravity feed applications it is recommended to be installed with the arrow in the opposite direction to the flow direction. Designed for a wide range of applications such as:

- Pulp and Paper.
- Mining.
- Effluent handling plants.
- Chemical plants.
- Food and beverage.
- Bulk conveying.
- Sewage applications.
- Chemical plants.

TECHNICAL DATA

Standard manufacturing sizes:

From DN50 up to DN2000

Working pressures:

From DN 50 to DN 125: 10

(kg/cm²)

DN 150: 8 (kg/cm²)

DN 200: 7 (kg/cm²)

From DN 250 to DN 300: 5

(kg/cm²)

From DN 350 to DN 400: 4

(kg/cm²)

From DN 450 to DN 600: 3

(kg/cm²)

From DN 700 to DN 1200: 2

(kg/cm²)

Flange connection drillings:

The standard flange connection is according to DIN PN10.

Other flange connections such as, ANSI 150, DIN PN6 – PN16 – PN25, British Standard, Australian Standard, JIS are available under request.

Applied Directives:

Directive 98/37/CE (machinery),

Directive 97/23/CE (PED: Group 2),

Directive 94/9/CE (ATEX: Group II, Cat. 3 /Zones 2 and 22)

Quality Dossier: All valves are hydrostatically tested at CMO with water and CMO material and test certificates can be provided.

Body test pressure = Maximum rated pressure x 1,5

Seat test pressure = Maximum rated pressure x 1,1

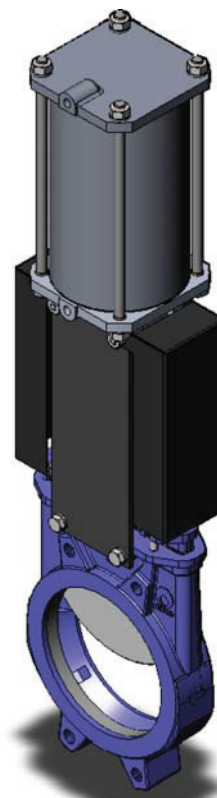

SERIES A

LUGGED TYPE

Series A is also available

Lugged type under request



ACCESORIES & ACTUATORS

- ✓ Any type of actuator available. Rising or non rising stem
- ✓ Any type of soft sealing: Nitrile, Viton, Silicon, PTFE etc. Also metal seat available
- ✓ All kind of accessories available: Deflector cone, Reinforced socket, Diaphragm, Mechanical Limit Switches, Inductive Switches and Positioners, Solenoid valves, Connection electrical boxes, electrical wiring and pneumatic piping, Stroke limiting mechanical stops, Mechanical locking device, Emergency manual actuator (hand wheel /gear box), Flushing Holes, Bonnet, etc.

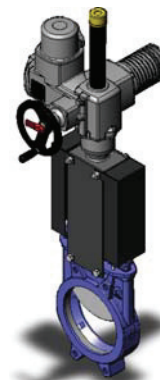
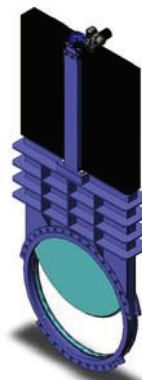
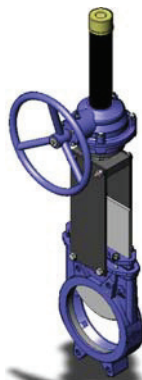

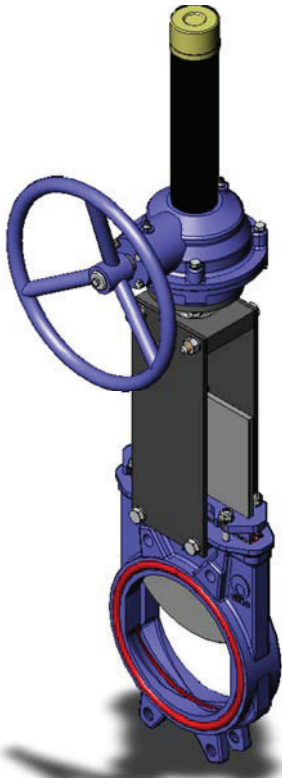

PRODUCT DESCRIPTION

Wafer style, **bidirectional** knife gate valve. One piece integral cast body with sliding wedges to provide bidirectional function. High flow rates with low pressure drops. Several seat and packing materials available. Face to face dimension according CMO standard.

GENERAL APPLICATIONS

This knife gate valve is appropriate for clean liquids or liquid with a solids concentration of maximum 4% on paper pulp applications and up to 35% of low density and dimension solids on sewage water applications. If application contains hard solids such as rocks, stones and similars then other Series for slurry must be used.

Designed for a wide range of applications such us:

- Effluent handling plants.
- Chemical plants.
- Food and beverage.
- Sewage applications.

In all these applications the installation of the valve is recommended after the fluid is screened to eliminate the solids or big parts contained on it.

TECHNICAL DATA

Standard manufacturing sizes:
From DN50 up to DN2000

Working pressures:
From DN 50 to DN 125: 10 (kg/cm²)
DN 150: 8 (kg/cm²)
DN 200: 7 (kg/cm²)
From DN 250 to DN 300: 5 (kg/cm²)
From DN 350 to DN 400: 4 (kg/cm²)
From DN 450 to DN 600: 3 (kg/cm²)
From DN 700 to DN 1200: 2 (kg/cm²)

Flange connection drillings:

The standard flange connection is according to DIN PN10.

Other flange connections such as, ANSI 150, DIN PN6 – PN16 – PN25, British Standard, Australian Standard, JIS are available under request.

Applied Directives:

Directive 98/37/CE (machinery),
Directive 97/23/CE (PED: Group 2), Directive 94/9/CE (ATEX: Group II, Cat. 3 /Zones 2 and 22)

Quality Dossier: All valves are hydrostatically tested at CMO with water and CMO material and test certificates can be provided.

Body test pressure = Maximum rated pressure x 1,5
Seat test pressure = Maximum rated pressure x 1,1

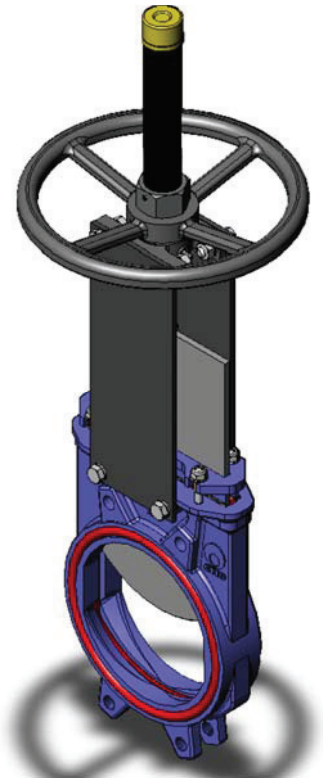

NEW SERIES AB FOR HIGH PRESSURES

FROM DN 700 TO DN 1600 FOR 6 BARS AND 10 BARS

- **OPTION 1: BODY IN STEEL S275JR, GATE AISI 304, EPDM SEAT**
- **OPTION 2: BODY IN CF8M, GATE IN AISI 316, EPDM SEAT**

ASK FOR MORE INFORMATION

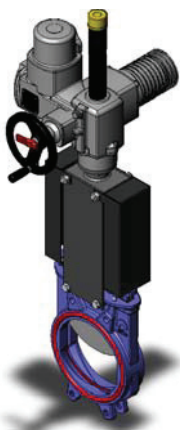
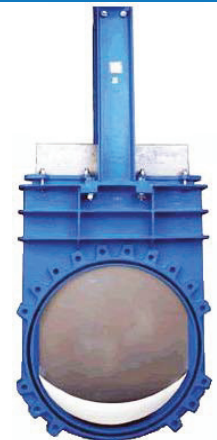

ACCESORIES & ACTUATORS

- ✓ Any type of actuator available except manual lever. Rising or non rising stem
- ✓ Any type of soft sealing: Nitrile, Viton, Silicon etc. Metal or PTFE Not available
- ✓ All kind of accesories available: Deflector cone, Reinforced socket, Diaphragm, Mechanical Limit Switches, Inductive Switches and Positioners, Solenoid valves, Connection electrical boxes, electrical wiring and pneumatic piping, Stroke limiting mechanical stops, Mechanical locking device, Emergency manual actuator (hand wheel /gear box)

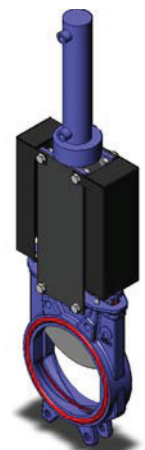

PRODUCT DESCRIPTION

Wafer style, bidirectional knife gate valve. Cast body, composed by two bolted parts, with inside sliding guides to provide a smooth operation. High flow rates with low pressure drops. Several seat and packing materials available. Face to face dimension according CMO standard.



GENERAL APPLICATIONS

This knife gate valve is appropriate for liquids with a solids concentration of maximum 8%. Low concentration fluids like paper pulp with low concentration, slurries, ... Designed for a wide range of applications such us:

- Pulp and Paper.
- Mining.
- Effluent handling plants.
- Chemical plants.
- Food and beverage.
- Bulk conveying.
- Sewage applications.
- Chemical plants.

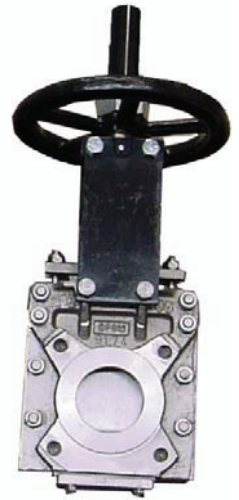

TECHNICAL DATA FOR B-U SERIES

Standard manufacturing sizes:

From DN80 up to DN600 (bigger sizes under request)

Working pressures:

From DN 80 to DN 125: 10 (kg/cm²) DN 150: 8 (kg/cm²) DN 200: 7 (kg/cm²)
 From DN 250 to DN 300: 5 (kg/cm²) From DN 350 to DN 400: 4 (kg/cm²)
 From DN 450 to DN 600: 3 (kg/cm²)

Flange connection drillings:

The standard flange connection is according to DIN PN10. Other flange connections such as, ANSI 150, DIN PN6 – PN16 – PN25, British Standard, Australian Standard, JIS Standard, are available under request.

Applied Directives:

Directive 98/37/CE (machinery), **Directive 97/23/CE (PED: Group 2)**, Directive 94/9/CE (ATEX: Group II, Cat. 3 / Zones 2 and 22)

Quality Dossier: All valves are hydrostatically tested at CMO with water and CMO material and test certificates can be provided.

Body test pressure = Maximum rated pressure x 1,5 Seat test pressure = Maximum rated pressure x 1,1

PRODUCT DESCRIPTION

Wafer style, unidirectional knife gate valve. Cast body, composed by two bolted parts, with inside sliding guides to provide a smooth operation. High flow rates with low pressure drops. Several seat and packing materials available. Face to face dimension according CMO standard. Arrow pointing in the flow direction in the valve body



GENERAL APPLICATIONS

High concentration flows and solids like granulated coal, also used for food applications and animal waste applications. If it is used for dry solids in gravity feed applications it is recommended to be installed with the arrow in the opposite direction to the flow direction. Designed for a wide range of applications such us:

- Pulp and Paper.
- Mining.
- Effluent handling plants.
- Food and beverage.
- Bulk conveying.
- Sewage applications.
- Chemical plants.

ACCESORIES FOR B-U SERIES

Mirror Polished Gate, PTFE Lined Gate, Stellite gate
 Scraper in the packing
 Air injection in the packing gland, Heating jacket, Flushing holes in body
 Mechanical Limit Switches, Inductive Switches and Positioners, Solenoid valves
 Connection electrical boxes, electrical wiring and pneumatic piping
 Stroke limiting mechanical stops, Mechanical locking device
 Emergency manual actuator (hand wheel /gear box)
 Triangular (V-notch) and pentagonal diaphragm with indication rule

PRODUCT DESCRIPTION

Flanged, unidirectional knife gate valve.
One piece fabricated (welded) body with guides to support the gate and seating wedges.
Several seat and packing materials available.
Standard manufacturing flange connection and face to face dimension according CMO standard, but also can be fully adapted according to the customer pipeline dimensions.

GENERAL APPLICATIONS

This knife gate valve is appropriate for powders and solids, without any liquid contain. It is mainly used for dry solids in gravity feed applications and for low working pressures.
Designed for a wide range of applications such as:

- Mining.
- Chemical plants.
- Food and beverage.
- Bulk conveying.

TECHNICAL DATA

Standard manufacturing sizes:
From 125x125 up to 1600x1600 mm
- Rectangular design also available
- Bigger sizes under request

Working pressures:
Standard: 0.5 Kg/cm²
For higher pressures please contact with our sales department.

Flange connection drillings:
The standard flange connection is according to CMO standard. Considering that it is a fabricated valve other flange connections are available under request.
The flange connection and face to face dimension of the valve can be completely adapted to the dimensions needed by the customer

Applied Directives:
Directive 98/37/CE (machinery),
Directive 97/23/CE (PED: Group 2),
Directive 94/9/CE (ATEX: Group II, Cat. 3 / Zones 2 and 22)

Quality Dossier:
Since they are valves to be working with powders and solid particles these valves are not hydrostatically tested with water. The tightness of the seating area is measured by gauges.
CMO material and test certificates can be provided.

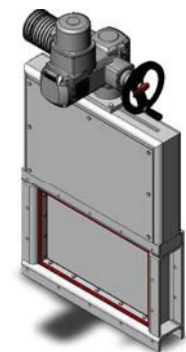
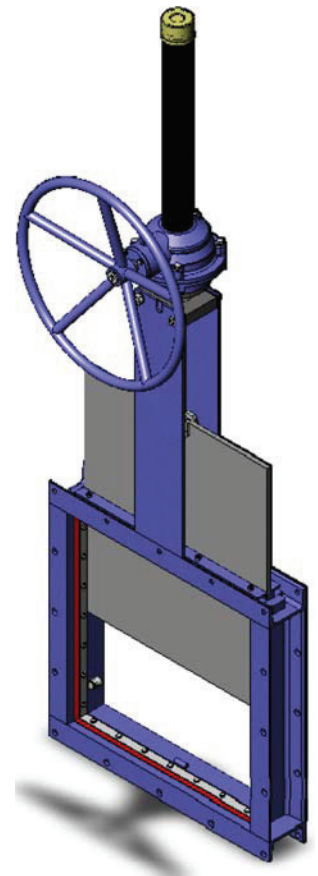
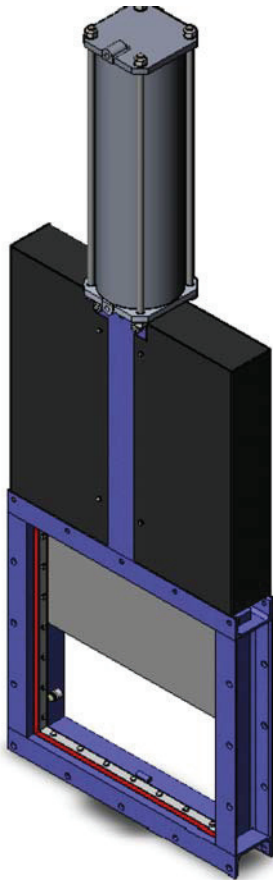

ACCESORIES & ACTUATORS

- ✓ Any type of actuator available. Rising or non rising stem
- ✓ Any type of soft sealing: Nitrile, Viton, Silicon, PTFE etc. Also metal seat available
- ✓ All kind of accesories available: Deflector cone, Mechanical Limit Switches, Inductive Switches and Positioners, Solenoid valves, Connection electrical boxes, electrical wiring and pneumatic piping, Stroke limiting mechanical stops, Mechanical locking device, Emergency manual actuator (hand wheel /gear box), Flushing Holes, Bonnet, etc.

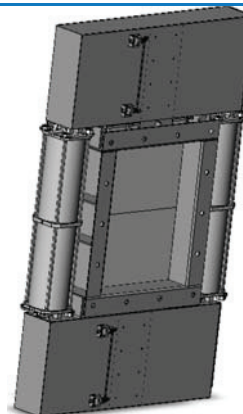
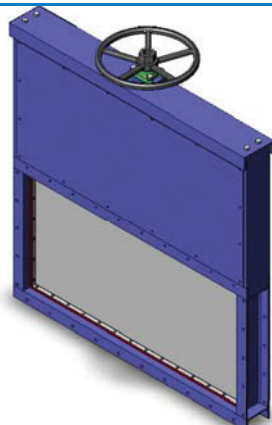

PRODUCT DESCRIPTION

Flanged unidirectional knife gate valve for high pressure applications
 One piece integral cast body with seating wedges and bolted bonnet.
 High flow rates with low pressure drops
 Several seat and packing materials available.
 Face to face dimension according to CMO standard.
 Arrow in the body pointing the flow direction

GENERAL APPLICATIONS

This knife gate valve is appropriate for clean liquids or liquids containing solid particles.
 Designed for a wide range of applications such as:

- Pulp and Paper.
- Mining.
- Effluent handling plants.
- Chemical plants.
- Food and beverage.
- Bulk conveying.
- Sewage applications.
- Pumping installations

Applied Directives:

Directive 98/37/CE (machinery),
 Directive 97/23/CE (PED: Group 2),
 Directive 94/9/CE (ATEX: Group II, Cat. 3 / Zones 2 and 22)

Quality Dossier:

All valves are hydrostatically tested at CMO with water and CMO material and test certificates can be provided.
 Body test pressure = Maximum rated pressure x 1,5
 Seat test pressure = Maximum rated pressure x 1,

TECHNICAL DATA

Standard manufacturing sizes:
 From DN50 up to DN2000 (bigger sizes under request)

Working pressures:

From PN2.5 up to PN100
 Each valve is designed according to the working conditions:
 For PN16 – Max. valve size DN1000
 For PN25 – Max. valve size DN800
 For PN40 – Max. valve size DN800
 For PN64 – Max. valve size DN600
 For PN100 – Max. valve size DN600

These pressures are to be applied on the valve following the direction of the arrow stamped on the body side. Due to the valve design with seating wedges it is allowed 50% of these pressures in the opposite direction of the arrow. Bidirectional design also available under request

Flange connection drillings:

The standard flange connection is according to DIN PN10 and Ansi B16.5 (Class 150)
 Other flange connections such as DIN PN6 – PN16 – PN25, British Standard, Australian Standard, JIS Standard, are available under request.

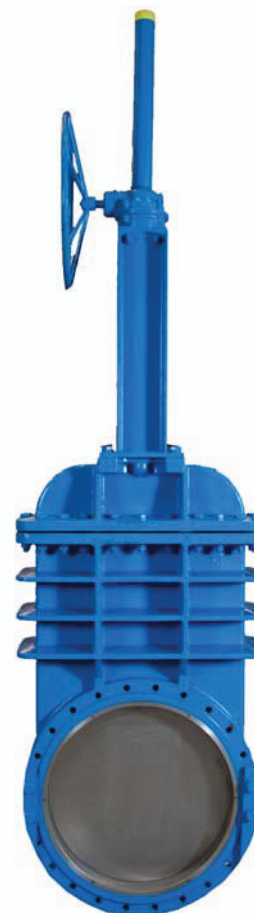
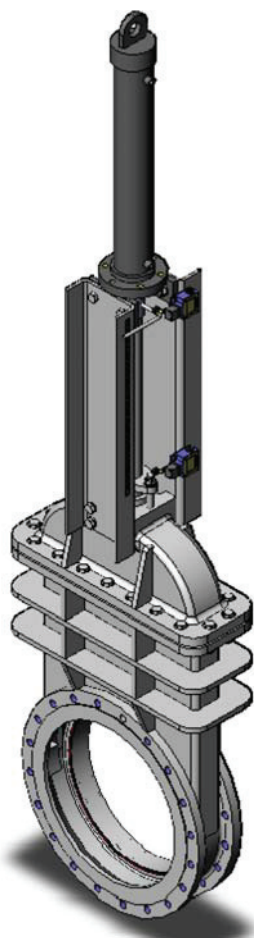

ACCESORIES & ACTUATORS

- ✓ Any type of actuator available. Rising or non rising stem
- ✓ Any type of soft sealing: Nitrile, Viton, Silicon, PTFE etc. Also metal seat available
- ✓ Mirror Polished Gate, PTFE Lined Gate, Stellite gate, Scraper in the packing, Air injection in the packing gland, Heating jacket, Flushing holes in body, Mechanical Limit Switches, Inductive Switches and Positioners, Solenoid valves, Connection electrical boxes, electrical wiring and pneumatic piping, Stroke limiting mechanical stops, Mechanical locking device, Emergency manual actuator (hand wheel /gear box), Triangular (V-notch) and pentagonal diaphragm with indication rule





PRODUCT DESCRIPTION

Wafer style, **unidirectional** knife gate valve. Cast body, composed by two bolted parts, with inside sliding guides to provide a smooth operation. Double gate design with two pneumatic actuators that provides full bore when opening. High flow rates with low pressure drops. Several seat and packing materials available. Face to face dimension according CMO standard.

GENERAL APPLICATIONS

This knife gate valve is recommended for Paper Industry and especially for “rejects handling” (impurities contained in paper fibres like metal clips, staples, wires and others).



TECHNICAL DATA FOR DT-E SERIES

Standard manufacturing sizes:
From DN80 up to DN600 (bigger sizes under request)

Working pressures:
From DN 80 to DN 125: 10 (kg/cm²) DN 150: 8 (kg/cm²) DN 200: 7 (kg/cm²)
From DN 250 to DN 300: 5 (kg/cm²) From DN 350 to DN 400: 4 (kg/cm²)
From DN 450 to DN 600: 3 (kg/cm²)

Flange connection drillings:
The standard flange connection is according to DIN PN10.
Other flange connections such as, ANSI 150, DIN PN6 – PN16 – PN25, British Standard, Australian Standard, JIS Standard, are available under request.

Applied Directives:
Directive 98/37/CE (machinery), **Directive 97/23/CE (PED: Group 2)**, Directive 94/9/CE (ATEX: Group II, Cat. 3 / Zones 2 and 22)

Quality Dossier: All valves are hydrostatically tested at CMO with water and CMO material and test certificates can be provided.
Body test pressure = Maximum rated pressure x 1,5 Seat test pressure = Maximum rated pressure x 1,1

PRODUCT DESCRIPTION

Wafer style, unidirectional knife gate valve with round to square flow pass. Cast body, composed by two bolted parts, with inside sliding guides to provide a smooth operation. High flow rates with low pressure drops. Several seat and packing materials available. Face to face dimension according CMO standard.

GENERAL APPLICATIONS

This knife gate valve is appropriate for very abrasive and difficult applications where the valve can suffer a big damage. It is mainly used in paper recycling plants located in pulper junk traps and in general in places where hard particles (like metal clips and stones) are present in the media.

It is always installed in horizontal position and the difference in section from the inlet (round) to the outlet (square and bigger) allows to the solids to move free avoiding the jamming of the gate.

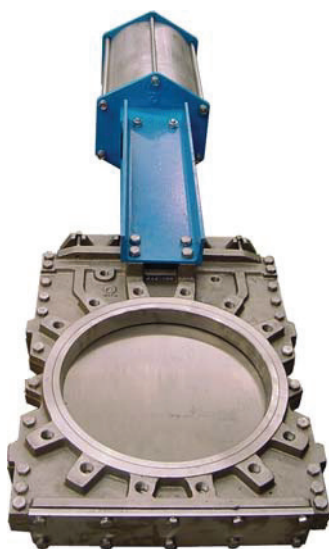

ACCESORIES FOR E – DT SERIES

Mirror Polished Gate, PTFE Lined Gate, Stellite gate
Scraper in the packing
Air injection in the packing gland, Heating jacket, Flushing holes in body
Mechanical Limit Switches, Inductive Switches and Positioners, Solenoid valves
Connection electrical boxes, electrical wiring and pneumatic piping
Stroke limiting mechanical stops, Mechanical locking device
Emergency manual actuator (hand wheel /gear box)
Triangular (V-notch) and pentagonal diaphragm with indication rule



PRODUCT DESCRIPTION

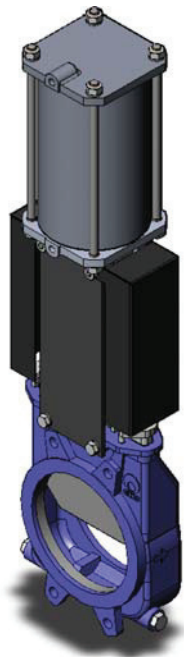

Wafer style, uni-directional knife gate valve. One piece integral cast body with guides to support the gate and seating wedges. High flow rates with low pressure drops. Several seat and packing materials available. Face to face dimension according CMO standard. Arrow in the body pointing the flow direction: In this type of knife gate valve the arrow points the flow direction in "off seating" direction. This means that the flow forces the gate to separate from the seat

GENERAL APPLICATIONS

This knife gate valve is appropriate for applications with dry products like dust, powders and grain, and as general rule, it is used for dry solids in gravity feed applications. Designed for a wide range of applications such us:

- Mining.
- Chemical plants.
- Food industry.
- Power plants.



TECHNICAL DATA FOR F – FK SERIES

Standard manufacturing sizes:
From DN50 up to DN1200 (bigger sizes under request)

Working pressures:
From DN 50 to DN 125: 3 (kg/cm²) DN 150: 2.5 (kg/cm²) DN 200: 2 (kg/cm²)
From DN 250 to DN 300: 1.5 (kg/cm²) From DN 350 to DN 400: 1.3 (kg/cm²)
From DN 450 to DN 600: 1 (kg/cm²) From DN 700 to DN 1200: 0.7 (kg/cm²)

Flange connection drillings:
The standard flange connection is according to DIN PN10. Other flange connections such as, ANSI 150, DIN PN6 – PN16 – PN25, British Standard, Australian Standard, JIS Standard, are available under request.

Applied Directives:
Directive 98/37/CE (machinery), **Directive 97/23/CE (PED: Group 2)**, Directive 94/9/CE (ATEX: Group II, Cat. 3 / Zones 2 and 22)

Quality Dossier: All valves are hydrostatically tested at CMO with water and CMO material and test certificates can be provided.
Body test pressure = Maximum rated pressure x 1,5 Seat test pressure = Maximum rated pressure x 1,1

PRODUCT DESCRIPTION



Wafer style, uni-directional knife gate valve. One piece integral cast body with guides to support the gate, seating wedges and **bonnet**. High flow rates with low pressure drops. Several seat and packing materials available. Face to face dimension according CMO standard. Arrow in the body pointing the flow direction: In this type of knife gate valve the arrow points the flow direction in "off seating" direction. This means that the flow forces the gate to separate from the seat.

GENERAL APPLICATIONS

This knife gate valve is appropriate for applications with dry products like dust, powders and grain containing air or gases. As a general rule, it is used for dry solids in gravity feed applications **containing also air or gases**.

Designed for a wide range of applications such us:

- Mining.
- Chemical plants.
- Food industry.
- Power plants.

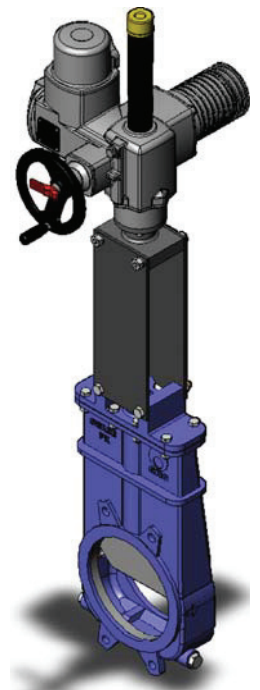

ACCESORIES FOR F – FK SERIES

Mirror Polished Gate
PTFE Lined Gate
Stellited gate
Scraper in the packing
Air injection in the packing gland
Heating jacket
Flushing holes in body
Mechanical Limit Switches, Inductive Switches and Positioners
Solenoid valves
Connection electrical boxes, electrical wiring and pneumatic piping
Stroke limiting mechanical stops
Mechanical locking device
Emergency manual actuator (hand wheel /gear box)
Triangular (V-notch) and pentagonal diaphragm with indication rule



PRODUCT DESCRIPTION

Wafer style, bidirectional knife gate valve. Cast body **monoblock type**, with inside sliding guides to provide a smooth operation. High flow rates with low pressure drops. Several seat and packing materials available. Face to face dimension according CMO standard.

GENERAL APPLICATIONS

This knife gate valve is specially recommended for mining industry in slurry transportation pipe lines (water with stones, mud etc) but it also can be used in other industries when working with abrasive slurries such as:

- Mining
- Chemical plants
- Fertilizer plants
- Sewage & Waste Water applications
- Pulp & Paper
- Power Generation

TECHNICAL DATA

Standard manufacturing sizes:
From DN50 up to DN600 (bigger sizes under request)

Working pressures:
From DN50 to DN600: 10 (kg/cm²) – 150PSI
Higher working pressures under request

Flange connection drillings:
The standard flange connection is according to DIN PN10 & ANSI 150
Other flange connections are available under request.

Applied Directives:
Directive 98/37/CE (machinery),
Directive 97/23/CE (PED: Group 2), Directive 94/9/CE (ATEX: Group II, Cat. 3 / Zones 2 and 22)

Quality Dossier: All valves are hydrostatically tested at CMO with water and CMO material and test certificates can be provided.
Body test pressure = Maximum rated pressure x 1.5
Seat test pressure = Maximum rated pressure x 1.1

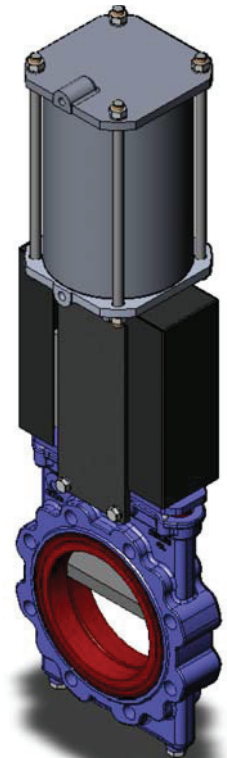

GM SERIES

Knife gate valve of double Cast Iron GG25 body bolted construction, for slurry applications and lower pressures.

- From DN 50 to DN 125: 10 (kg/cm²)
- DN 150: 8 (kg/cm²)
- DN 200: 7 (kg/cm²)
- From DN 250 to DN 300: 5 (kg/cm²)
- From DN 350 to DN 400: 4 (kg/cm²)
- From DN 450 to DN 600: 3 (kg/cm²)
- From DN 700 to DN 1200: 2 (kg/cm²)

ASK FOR MORE INFORMATION

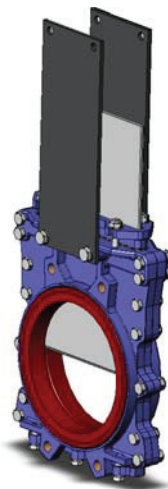

ACCESORIES & ACTUATORS

- Mirror Polished Gate
- Stellited gate
- PTFE Lined Gate
- Scraper in the packing
- Air injection in the packing gland
- Mechanical Limit Switches, Inductive Switches and Positioners
- Solenoid valves
- Connection electrical boxes, electrical wiring and pneumatic piping
- Stroke limiting mechanical stops
- Mechanical locking device
- Emergency manual actuator (hand wheel /gear box)

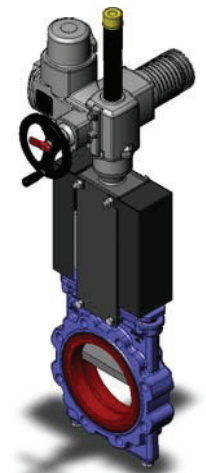

PRODUCT DESCRIPTION

Wafer style, uni-directional knife gate valve. Bidirectional (optional)
One piece integral cast body with guides to support the gate, seating wedges and **bolted bonnet**.

High flow rates with low pressure drops.
Several seat and packing materials available.

Face to face dimension according CMO standard.

Arrow on the body pointing the flow direction.

GENERAL APPLICATIONS

This knife gate valve is appropriate for **clean liquids and gases** (without solids). If a small percentage of dust or powder is present in the fluid its vertical installation is recommended.

Designed for a wide range of applications such us:

- Water applications.
- Pneumatic transports.
- Liquid bitumen handling
- Industrial applications.



TECHNICAL DATA

Standard manufacturing sizes:

From DN50 up to DN1200 (bigger sizes under request)

Working pressures:

From DN 50 to DN 125: 10 (kg/cm²)
DN 150: 8 (kg/cm²)
DN 200: 7 (kg/cm²)
From DN 250 to DN 300: 5 (kg/cm²)
From DN 350 to DN 400: 4 (kg/cm²)
From DN 450 to DN 600: 3 (kg/cm²)
From DN 700 to DN 1200: 2 (kg/cm²)

Flange connection drillings:

The standard flange connection is according to DIN PN10.

Other flange connections such as, ANSI 150, DIN PN6 – PN16 – PN25, British Standard, Australian Standard, JIS Standard, are available under request.

Applied Directives:

Directive 98/37/CE (machinery), **Directive 97/23/CE (PED: Group 2)**, Directive 94/9/CE (ATEX: Group II, Cat. 3 / Zones 2 and 22)

Quality Dossier:

Body test pressure = Maximum rated pressure x 1,5

Seat test pressure = Maximum rated pressure x 1,1

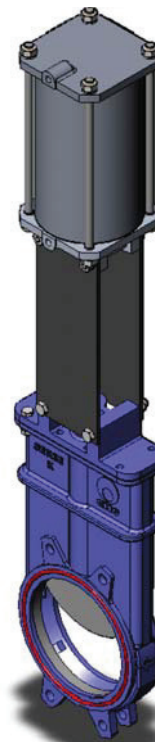

ACCESORIES & ACTUATORS

- Mirror Polished Gate
- Stellited gate
- PTFE Lined Gate
- Scraper in the packing
- Air injection in the packing gland
- Mechanical Limit Switches, Inductive Switches and Positioners
- Solenoid valves
- Connection electrical boxes, electrical wiring and pneumatic piping
- Stroke limiting mechanical stops
- Mechanical locking device
- Emergency manual actuator (hand wheel /gear box)

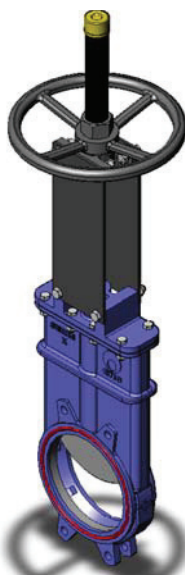

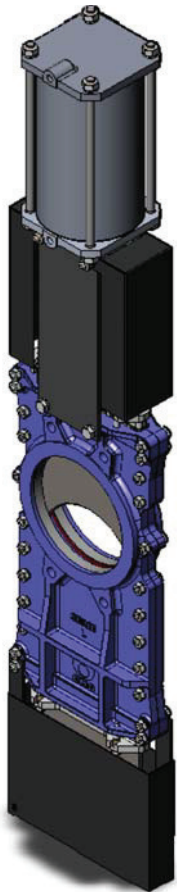

PRODUCT DESCRIPTION

Wafer style, bidirectional knife gate valve.
 Cast body, composed by two bolted parts, with inside sliding guides to provide a smooth operation.
 High flow rates with low pressure drops.
 Several seat and packing materials available.
 Face to face dimension according CMO standard.

GENERAL APPLICATIONS

This knife gate valve is appropriate for liquids with a solids concentration of maximum 20%.
 It is also recommended in applications under silos with dry and fine particles because of the way in which cuts the flow and high consistency mediums.
 Designed for a wide range of applications such us:

- Pulp and Paper.
- Mining.
- Effluent handling plants.
- Chemical plants.
- Food and beverage.
- Bulk conveying.
- Sewage applications.
- Chemical plants.

TECHNICAL DATA

Standard manufacturing sizes:
 From DN50 up to DN1200 (bigger sizes under request)

Working pressures:
 From DN 50 to DN 125: 10 (kg/cm²)
 DN 150: 8 (kg/cm²)
 DN 200: 7 (kg/cm²)
 From DN 250 to DN 300: 5 (kg/cm²)
 From DN 350 to DN 400: 4 (kg/cm²)
 From DN 450 to DN 600: 3 (kg/cm²)
 From DN 700 to DN 1200: 2 (kg/cm²)

Flange connection drillings:
 The standard flange connection is according to DIN PN10.
 Other flange connections such as, ANSI 150, DIN PN6 – PN16 – PN25, British Standard, Australian Standard, JIS Standard, are available under request.

Applied Directives:
 Directive 98/37/CE (machinery),
 Directive 97/23/CE (PED: Group 2),
 Directive 94/9/CE (ATEX: Group II, Cat. 3 / Zones 2 and 22)

Quality Dossier: All valves are hydrostatically tested at CMO with water and CMO material and test certificates can be provided.
 Body test pressure = Maximum rated pressure x 1.5
 Seat test pressure = Maximum rated pressure x 1.1

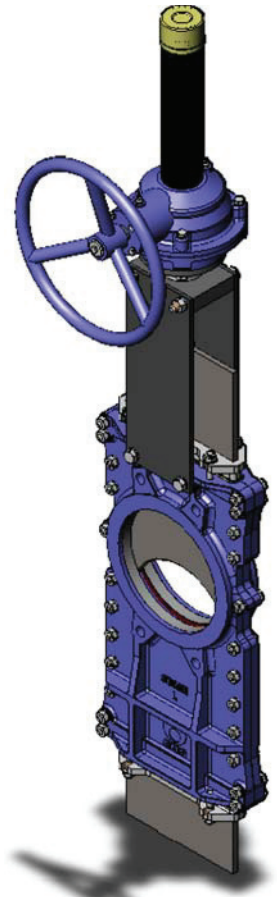

ACCESORIES & ACTUATORS

- ✓ Any type of actuator available except manual lever. Rising or non rising stem
- ✓ Any type of soft sealing: Nitrile, Viton, Silicon etc. Metal or PTFE Not available
- ✓ Mirror Polished Gate, PTFE Lined Gate, Stellite gate, Scraper in the packing, Air injection in the packing gland, Heating jacket, Flushing holes in body, Mechanical Limit Switches, Inductive Switches and Positioners, Solenoid valves, Connection electrical boxes, electrical wiring and pneumatic piping, Stroke limiting mechanical stops, Mechanical locking device, Emergency manual actuator (hand wheel /gear box), Triangular (V-notch) and pentagonal diaphragm with indication rule

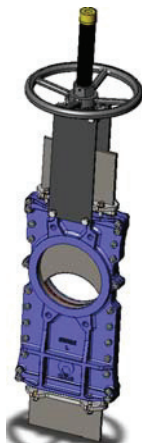

PRODUCT DESCRIPTION

Wafer style swing (also called tilting disc) check valve. Also flanged construction available under request.
One piece integral cast body with conically shaped inside to allow easy flowing of solid particles.
Face to face dimension according CMO standard.
Arrow in the body pointing the flow direction.

GENERAL APPLICATIONS

This valve is appropriate for liquids with a solids concentration of maximum 5%.

Designed for a wide range of applications such as:

- Pulp and Paper.
- Effluent handling plants.
- Chemical plants.
- Food and beverage.
- Sewage applications.



TECHNICAL DATA

Standard manufacturing sizes:
From DN50 up to DN1200 (bigger sizes under request)

Working pressures:
Diameters DN 50 to DN 600:
From 10 (kg/cm²) to 64 (kg/cm²)

Diameters DN 700 to DN 1200:
From 10 (kg/cm²) to 25 (kg/cm²)

Flange connection:

The standard flange connection is according to DIN PN10.
Other flange connections such as, ANSI 150, DIN PN6 – PN16 – PN25, British Standard, Australian Standard, JIS Standard, are available under request.

Applied Directives:

Directive 98/37/CE (machinery),
Directive 97/23/CE (PED: Group 2),
Directive 94/9/CE (ATEX: Group II, Cat. 3 / Zones 2 and 22)

Quality Dossier: All valves are hydrostatically tested at CMO with water and CMO material and test certificates can be provided.
Body test pressure = Maximum rated pressure x 1,5
Seat test pressure = Maximum rated pressure x 1,1 (Excellent tightness according to API 598)



NEW SERIES R FOR COMBINED CYCLE PLANTS

Combination of Flanged type Check Valve and Butterfly Valve with Hydraulic Cylinder and Counterweight used in Combined Cycle Power Stations

ASK FOR MORE INFORMATION

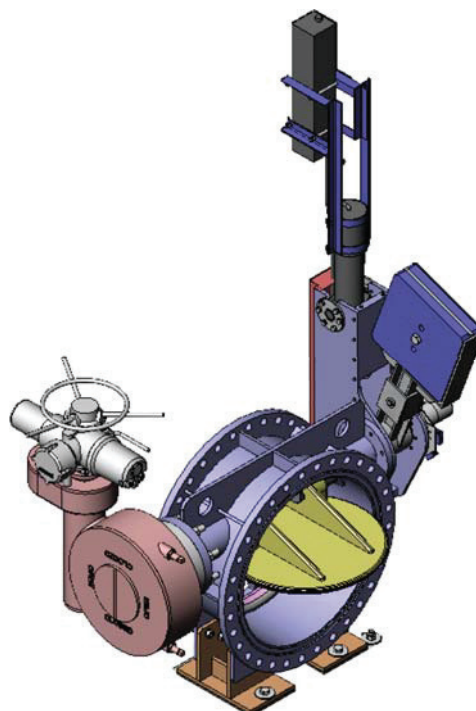

ACCESORIES & ACTUATORS



Spring Loaded Disc The check valves can be supplied with a stainless steel spring on the shaft which will help during the closing operation and increase the closing speed.

Counterweight and Shock Absorber

The counterweight and shock absorber system is used to control the closing speed of the disc and, at the same time, reduce the effects of the water hammer.
The shock absorber is composed by a hydraulic cylinder and an oil tank which are connected by hydraulic piping.

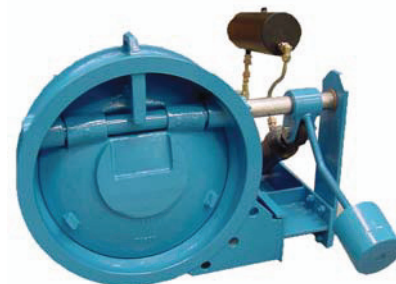

PRODUCT DESCRIPTION

Lugged style, uni-directional (optional bidirectional design) knife gate valve designed according with **MSS-SP-81** and **TAPPI TIS 405-8** standards. One piece integral cast body with guides to support the gate and seating wedges. High flow rates with low pressure drops. Several seat and packing materials available. Two face to face dimensions available: according CMO standard and according to TAPPI standard. Arrow in the body pointing the flow direction.

GENERAL APPLICATIONS

This knife gate valve is appropriate for liquids with a solids concentration of maximum 5%. If it is used for dry solids in gravity feed applications it is recommended to be installed with the arrow in the opposite direction to the flow direction.

Designed for a wide range of applications such as:

- Pulp and Paper.
- Mining.
- Effluent handling plants.
- Chemical plants.
- Food and beverage.
- Bulk conveying.
- Sewage applications.
- Chemical plants.

TECHNICAL DATA

Standard manufacturing sizes:

From DN50 up to DN1200 (bigger sizes under request)

Working pressures:

From DN 50 to DN 600: 10 (kg/cm²) – 150psi (bigger sizes under request)

Flange connection drillings:

The standard flange connection is according to DIN PN10.

Other flange connections such as, ANSI 150, DIN PN6 – PN16 – PN25, British Standard, Australian Standard, JIS are available under request.

Flange connection drillings:

The standard flange connection is according to DIN PN10 and Ansi B16.5 (Class 150)

Other flange connections such as DIN PN6 – PN16 – PN25, British Standard, Australian Standard, JIS Standard, are available under request.

Applied Directives:

Directive 98/37/CE (machinery), **Directive 97/23/CE (PED: Group 2)**, Directive 94/9/CE (ATEX: Group II, Cat. 3 / Zones 2 and 22)

Quality Dossier: All valves are hydrostatically tested at CMO with water and CMO material and test certificates can be provided.

Body test pressure = Maximum rated pressure x 1,5
Seat test pressure = Maximum rated pressure x 1,1

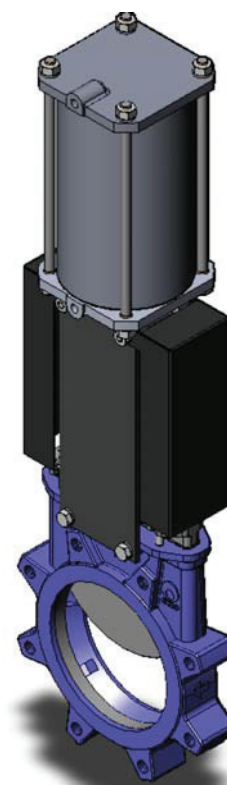

ACCESORIES & ACTUATORS

- ✓ Any type of actuator available. Rising or non rising stem
- ✓ Any type of soft sealing: Nitrile, Viton, Silicon, PTFE etc. Also metal seat available
- ✓ All kind of accesories available: Deflector cone, Reinforced socket, Diaphragm, Mechanical Limit Switches, Inductive Switches and Positioners, Solenoid valves, Connection electrical boxes, electrical wiring and pneumatic piping, Stroke limiting mechanical stops, Mechanical locking device, Emergency manual actuator (hand wheel /gear box), Flushing Holes, Bonnet, etc.

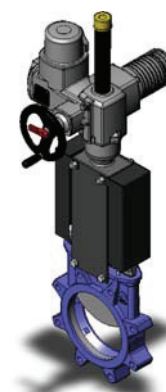
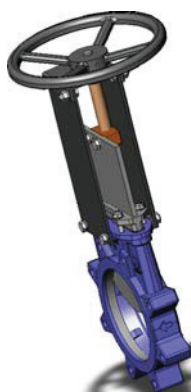

PRODUCT DESCRIPTION

3 or 4 ways plug valves. T shape, L shape and straight pass options.

GENERAL APPLICATIONS

Paper stock distribution.
Actuators: Manual, pneumatic, electric

TECHNICAL DATA

Standard manufacturing sizes:

From DN50 up to DN300 - Bigger Sizes under request

Working pressures:

From DN 50 to DN 300: 10 (kg/cm²)

Flange connection drillings:

The standard flange connection is according to DIN PN10.
Other flange connections such as, ANSI 150, DIN PN6 – PN16 – PN25,
British Standard, Australian Standard, JIS are available under request.

Applied Directives:

Directive 98/37/CE (machinery), **Directive 97/23/CE (PED: Group 2)**,

Directive 94/9/CE (ATEX: Group II, Cat. 3 /Zones 2 and 22)

Quality Dossier: All valves are hydrostatically tested at CMO with water and CMO material and test certificates can be provided.

Body test pressure = Maximum rated pressure x 1,5

Seat test pressure = Maximum rated pressure x 1,1

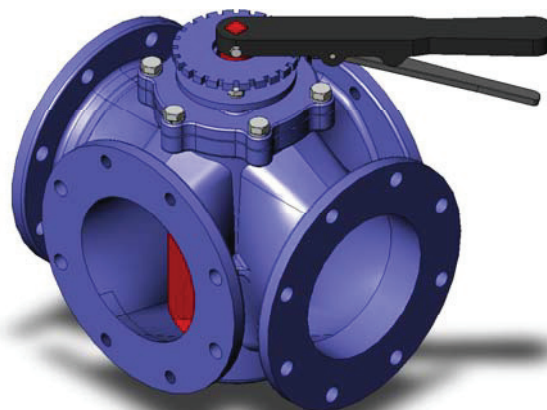
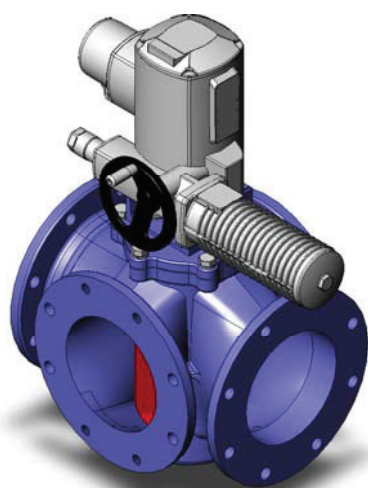
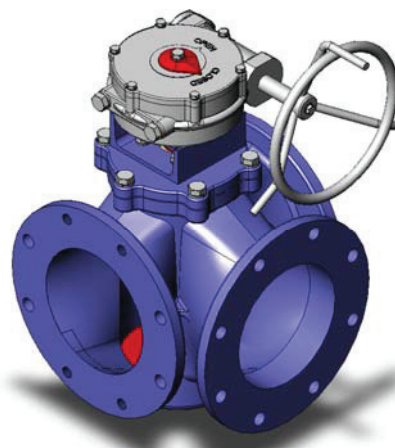
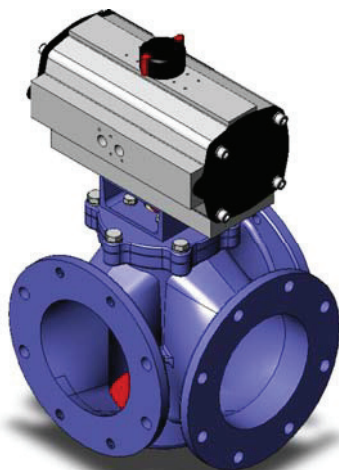
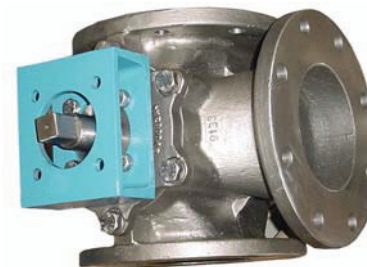



PENSTOCKS AND VALVES FOR WATER PROJECTS



PRODUCT DESCRIPTION

Standard construction with body and sleeve in carbon steel with stainless steel sliding side. Sealing between stainless steel and EPDM joint.

Standard actuator: Two hydraulic cylinders (one on each side).

Other options available like electric actuator. The valve is controlled by and hydraulic power unit and an electrical panel. Remote and local controls available.

APPLICATION

Installation on line in water dams for water flow control mainly to reduce water speed

Function: Flow speed reduction on line, also used as level regulator at big water deposits normally actuated by a floating system



TECHNICAL DATA FOR AN

Standard manufacturing sizes:

From DN 250 up to DN 2500 (bigger sizes under request)

Working pressures:

60 MCA Higher pressures available under request

Flange connection drillings:

The standard flange connection is according customer's requirements

Applied Directives:

Directive 98/37/CE (machinery)

Tightness 100%



PRODUCT DESCRIPTION

Standard construction with body and gates in carbon steel with stainless steel sliding side. Sealing between stainless steel and EPDM joint.

Standard actuator: Motor, Manual Gear...

APPLICATION

Installation on line in water dams or similar applications for water flow control mainly to reduce water speed

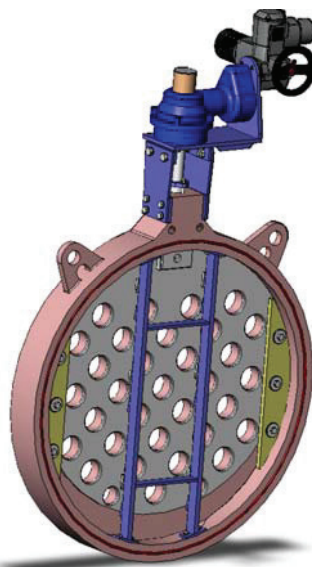

TECHNICAL DATA FOR CM

Standard manufacturing sizes:

From DN 250 up to DN 2500 (bigger sizes under request)

Working pressures:

60 MCA Higher pressures available under request

Flange connection drillings:

The standard flange connection is according customer's requirements

Applied Directives:

Directive 98/37/CE (machinery)

Tightness 100%



PRODUCT DESCRIPTION

AT series sliding gate for big dimensions. Tight bottom and sides (tightness in 3 sides). EPDM sealings fixed to the gate with an stainless steel flange.

The gate is manufactured with welded construction and as standard the most usual materials are carbon steel and stainless steel with different grades. Gate fabricated with UPN profiles to allow an easy installation in concrete.

The gate can be adapted completely to the requirements of the customer. Because of its construction it can be designed for different pressures and heights using several types of extensions and also gates designs.

Actuators: Hand-drivers, electric actuators., hydraulic actuators.....

APPLICATION

Control of fluids in channels with big dimensions.

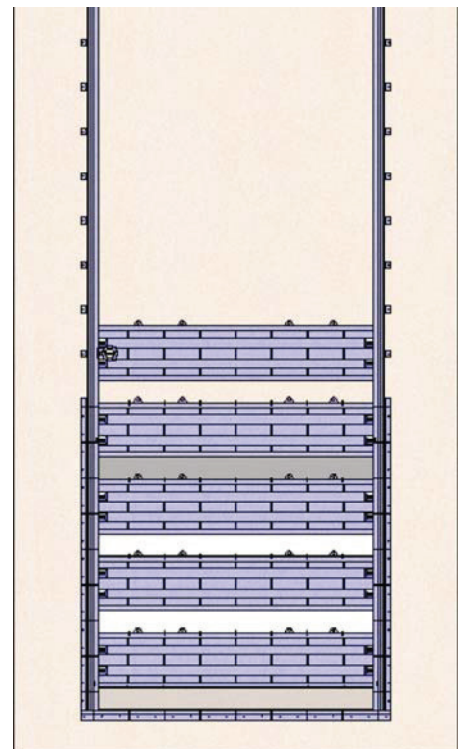
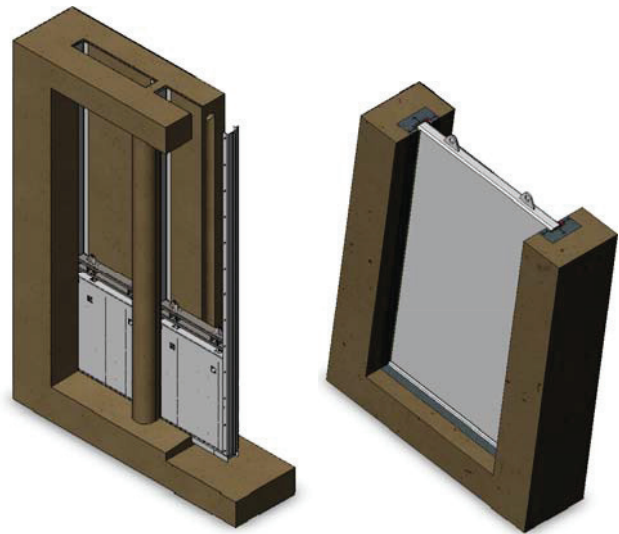
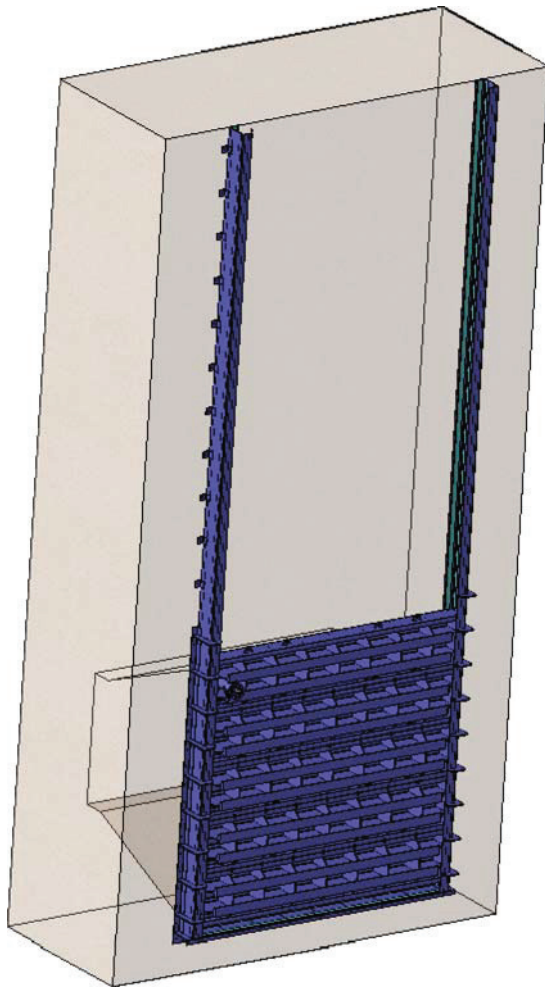

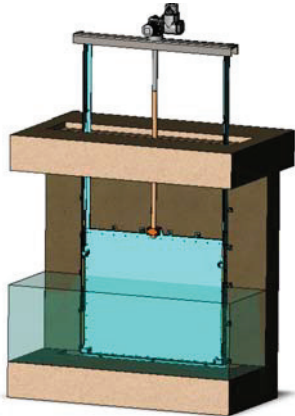

PRODUCT DESCRIPTION

Wall fitting gate with square, rectangular or round section. Sealings in EPDM or Brass + EPDM.

Welded construction being standard manufacturing materials carbon steel and stainless steel.

The gate can be adapted 100% to the customer requirements. Due to its construction it can be designed for different water pressures and heights using several kinds of extensions.

Actuators: handwheel, bevel gear, pneumatic double acting and single acting, electric actuator, hydraulic actuator

APPLICATION

Usually used for sewage treatment plants. Also can be used to control fluids in tanks and piping outlets fitting the gate to the wall.

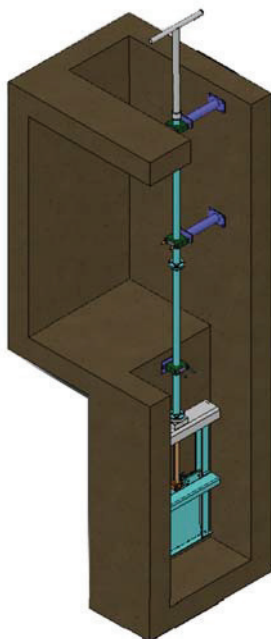
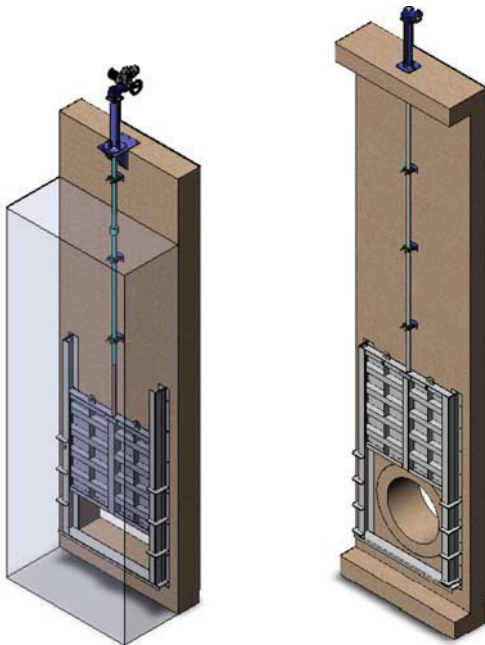

PRODUCT DESCRIPTION

Gate for open channel. Tightness in the bottom and both sides (3 sides). Sealings by EPDM joint or brass + EPDM.

Gate with welded construction. Standard manufacturing materials are carbon steel and stainless steel.

The gate can be adapted 100% to the customer requirements. Due to its construction it can be designed for different water pressures and heights using several kinds of extensions.

Actuators: handwheel, bevel gear, pneumatic double acting and single acting, electric actuator, hydraulic actuator

APPLICATION

Usually used for sewage treatment plants. Installation in channel for regulation of fluids. Due to the 3 side tightness the maximum height of water always will be the height of the gate itself.

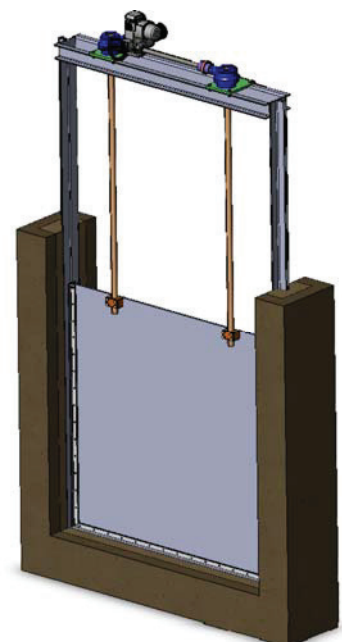
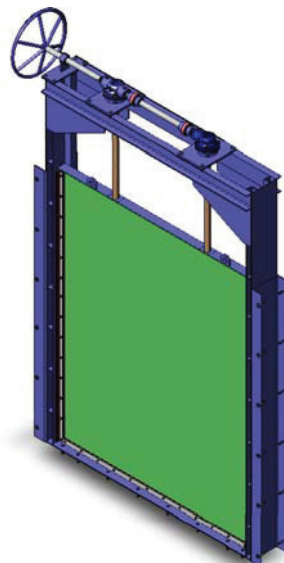
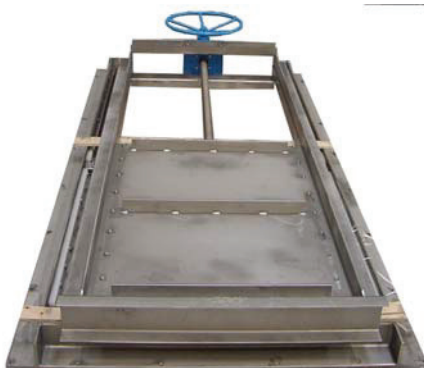
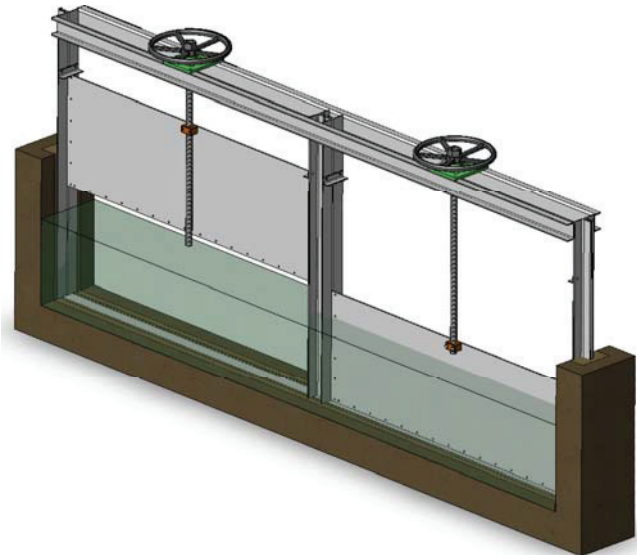
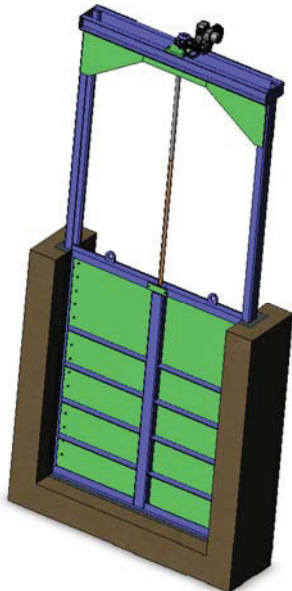
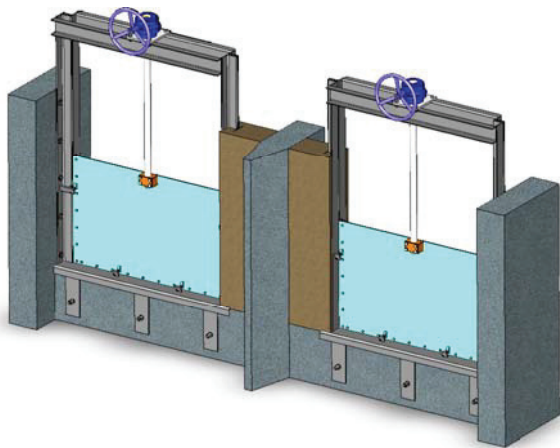



PRODUCT DESCRIPTION

Gate for open channel. Tightness in the bottom and both sides (3 sides). Sealings by EPDM joint or brass + EPDM.

Gate with welded construction. Standard manufacturing materials are carbon steel and stainless steel.

The gate can be adapted 100% to the customer requirements. Due to its construction it can be designed for different water pressures and heights using several kinds of extensions.

Actuators: handwheel, bevel gear, pneumatic double acting and single acting, electric actuator, hydraulic actuator

APPLICATION

The overflow gate valve is used to control the level of fluids in tanks. It also can be used to discharge by overflow solids and foams that are floating in the surface of the liquids.

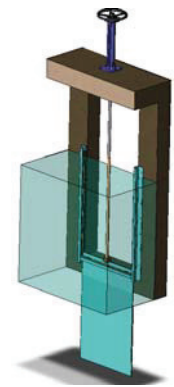
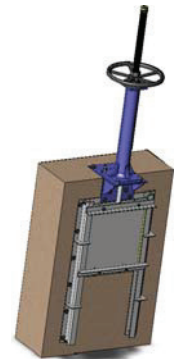
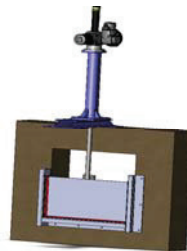

PRODUCT DESCRIPTION

Check valve to be installed at the end of pipe. Standard working pressure 2,5 meters

Round, square or rectangular welded construction. Manufacturing materials: carbon steel or stainless steel. Cast iron construction for small sizes.

Tightness by EPDM seat.
Two types of design are available:
- Straight seat / straight disk.
- Inclined seat / straight disk.

GENERAL APPLICATIONS

Valve to be fixed at the end of a pipeline. The fixing way can be flanged or prepared to installation in concrete.
Its design avoids to the fluid to return in the opposite direction of the flow

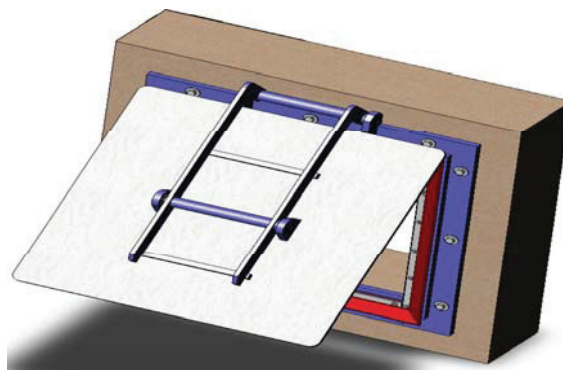
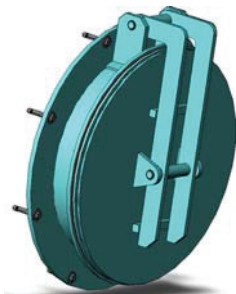
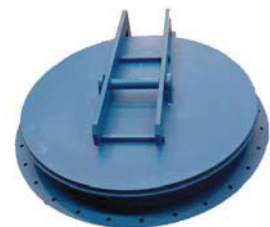

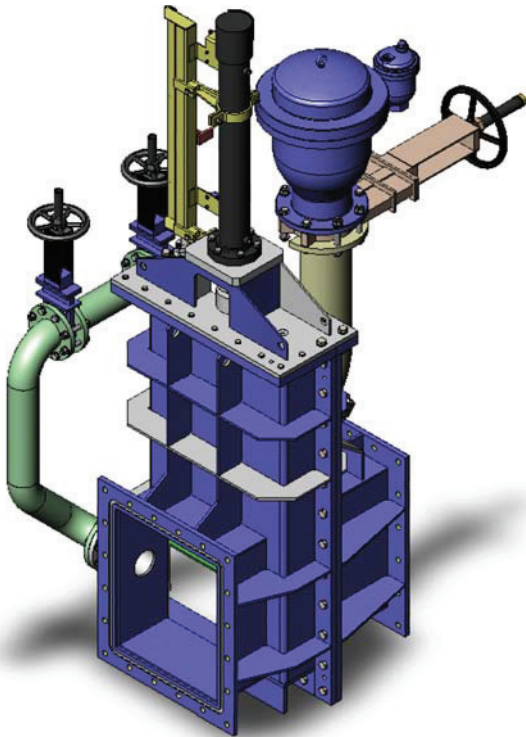

PRODUCT DESCRIPTION

Square or rectangular construction manufactured in carbon steel as standard. The dimensions of the valve can be completely adapted to the customer requirements.

As standard designed for 50 mWC with possibility to be designed for higher or lower pressures.

The gate is actuated by an hydraulic cylinder. As an option, an hydraulic or mechanical locking device can be installed to fix the gate in open position. An indication rule, by pass system and aeration piping is included in the valve. The hydraulic actuator is controlled by an hydraulic power unit and an electrical panel.

Accessories: Welded construction to change from square to round section.

APPLICATION

Installation in water dams to control the water coming from the lake. Normally two valves are installed in the same pipe, one for water controlling purposes and the other one as safety valve or for maintenance purposes.

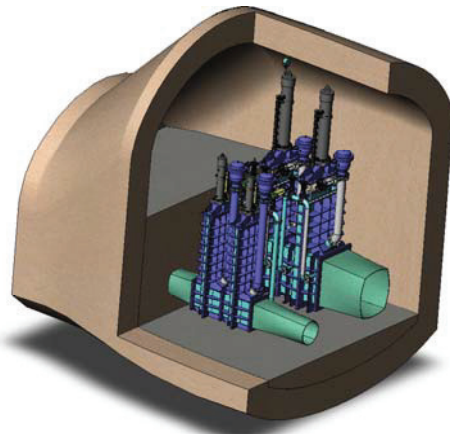
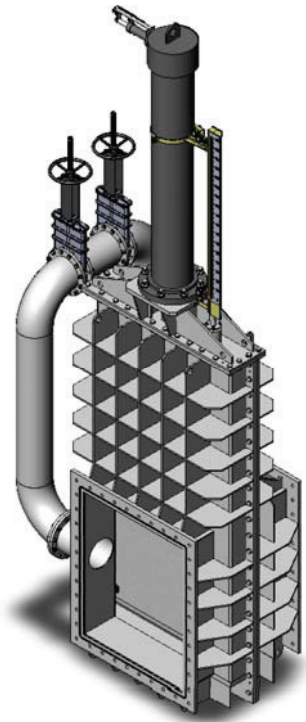

PRODUCT DESCRIPTION

Inside of our manufacturing range there are two different types of radial gates:

a) Surface type

Radial gate tight is 3 sides (bottom and sides). Manufactured in carbon steel with welded construction according to the customer requirements. Radial opening and closing against a turning shaft. Actuators: hydraulic, electric ...

b) Bottom type

Radial gate tight in 4 sides. Manufactured in carbon steel with welded construction according to the customer requirements.

Radial opening and closing against a turning shaft. Actuators: hydraulic, electric ...

APPLICATION

Surface radial gate: Level control of fluids

Bottom radial gate: Discharge of water in water dams

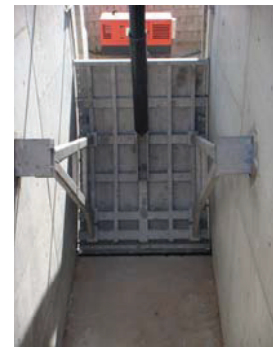
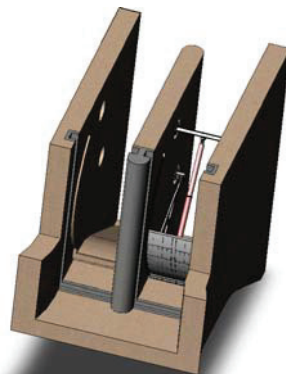
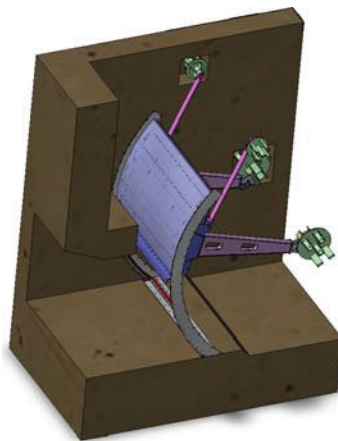
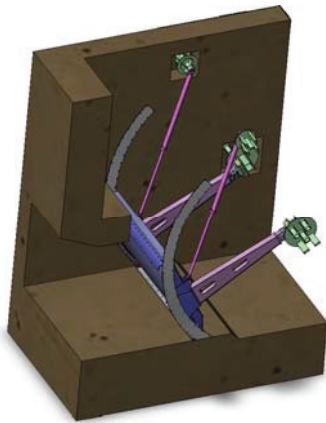

PRODUCT DESCRIPTION

Hinged gate with the gyratory axle in the channel bottom (GI Series) or on the upper side (GS Series).

Gate with welded construction. Standard manufacturing materials are carbon steel and stainless steel.

The gate can be adapted 100% to the customer requirements. Due to its construction it can be designed for different water pressures and heights using several kinds of extensions.
Actuators: handwheel, bevel gear, pneumatic double acting and single acting, electric actuator, hydraulic actuator

APPLICATION

Regulation of flows in channels and level control

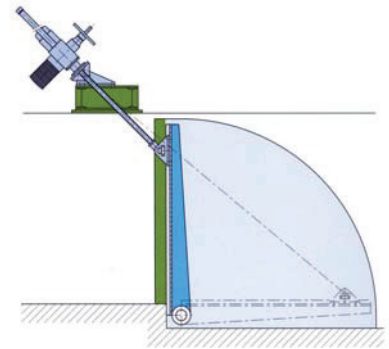

GI SERIES

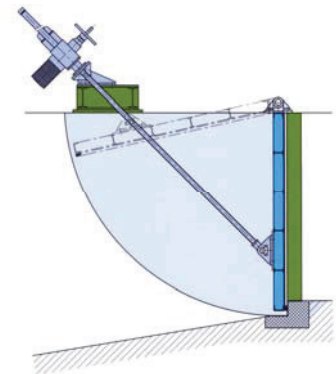
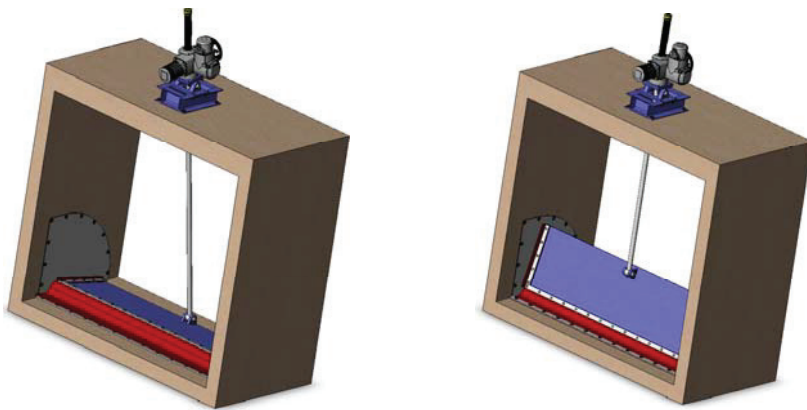

GS SERIES

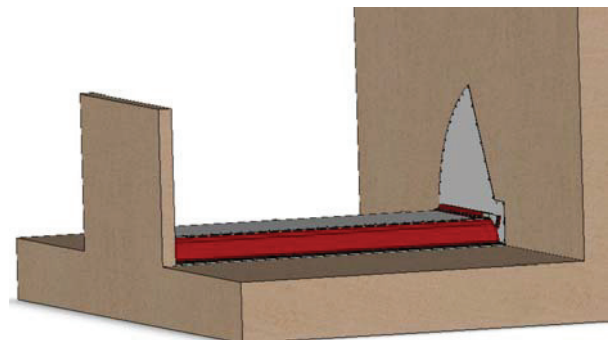
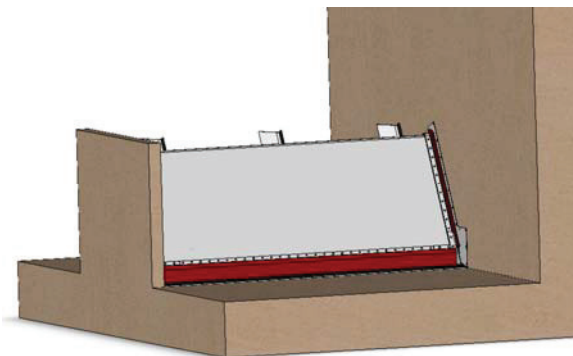

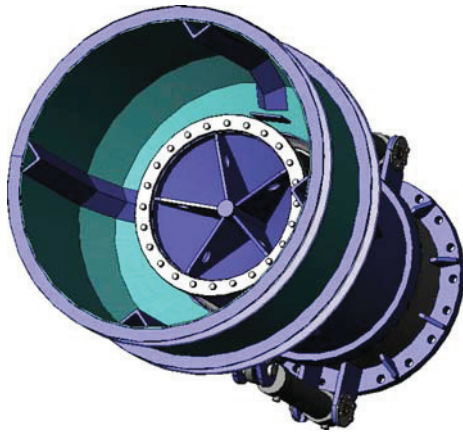

PRODUCT DESCRIPTION

Manufacturing range: from DN50 up to DN2500 (bigger sizes under request)
 Standard construction with body and sleeve in carbon steel with stainless steel sliding side.
 Sealing between stainless steel and EPDM joint.

Standard actuator: Two hydraulic cylinders (one on each side).

Other options available like electric actuator. The valve is controlled by and hydraulic power unit and an electrical panel. Remote and local controls available.

The valve can be designed to work submerged.

APPLICATION

Installation in water dam for water discharge control.
 Function: Eliminate the kinetic energy of the flow coming from the dam by an expansion process avoiding damage in the river.

ACCESORIES

Accessories to control the expansion of the flow:

- 1) Hood or fixed cone
- 2) Concentrator

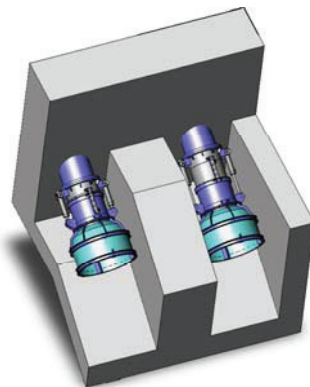
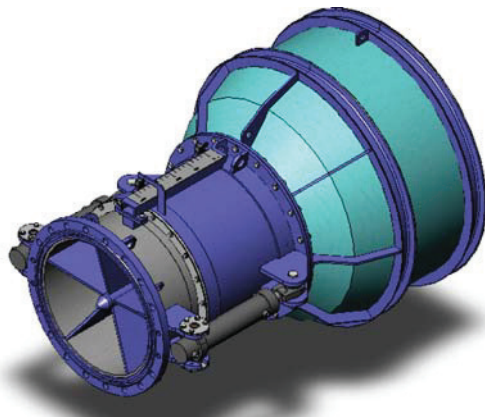

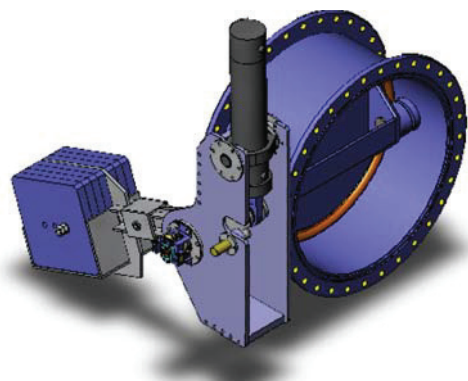

PRODUCT DESCRIPTION

Flanged butterfly valve with single or double eccentricity. Manufacturing range from DN 50 up to DN 2000 (bigger sizes under request).

The valve can be designed according to different standards: DIN (PN6, PN10, PN25, PN40, PN64), ANSI, AWWA Body and disk manufactured in carbon steel or stainless (different grades available) . The EPDM joint is fixed to body with an stainless steel flange..

The standard design is with single eccentric shaft but it can be manufactured with double eccentric shaft as well. The shaft of the valve is supported by self lubricated rings.

Actuators: Electric actuator, hydraulic actuator, hydraulic actuator + counterweight, manual actuator



APPLICATION

Hydroelectric power plants as guard valve to protect the turbine.
Water pumping applications as in combined cycle thermal power plants

ACCESORIES

- Speed detector – Electrical & Mechanical
- Limit Switches
- Piping
- Flanges
- Dismantling Joint
- Air Valves
- By pass
- Hydraulic Control Unit
- Electrical Control Panel

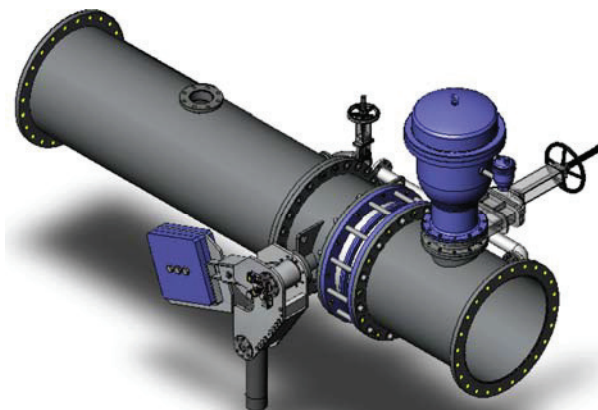
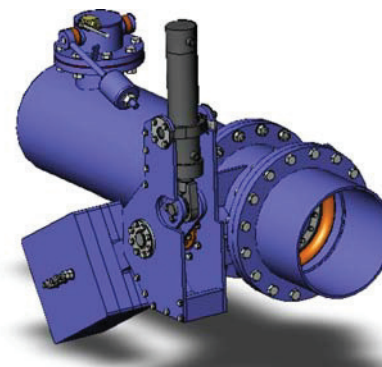
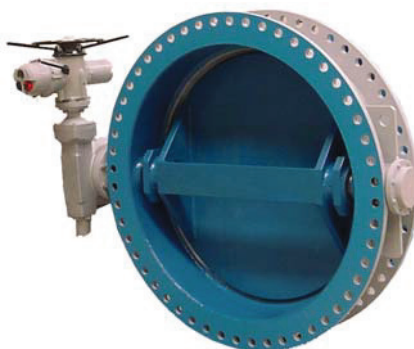
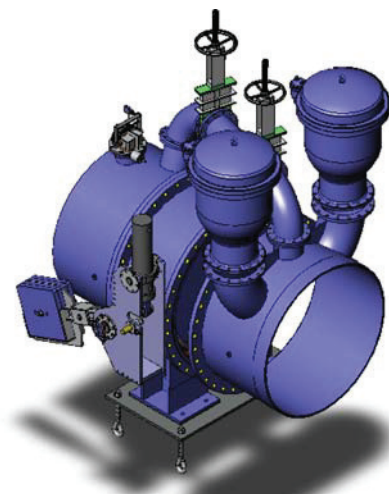

PRODUCT DESCRIPTION

Rolling wall-fitting gate. Four sided seal. As serie MC, but for large sizes or water heights. Tightness in the bottom, upper part and both sides (4 sides). EPDM sealing joints fixed to the gate by an stainless steel flange.

Welded construction in carbon steel or stainless steel as standard. External frame manufactured with U shape profiles for installation in concrete.

The design includes wheels for a proper sliding of the gate into the frame. It can be adapted completely to the customer requirements. Due to its construction it can be desgined for different pressures and using different kind of extensions can be fitted to every civil work.

Actuators: Hand operated, electric actuator, hydraulic actuator

APPLICATION

Control of fluids in great dimension ducts

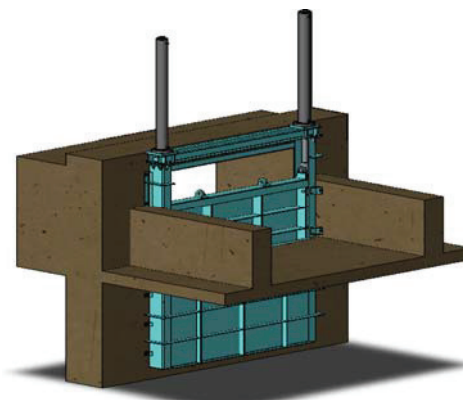
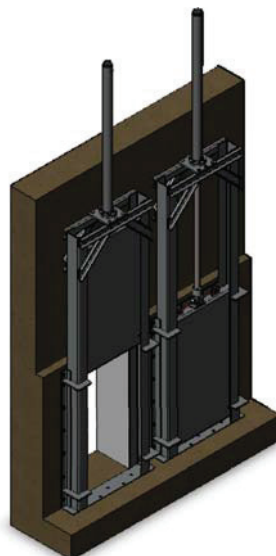
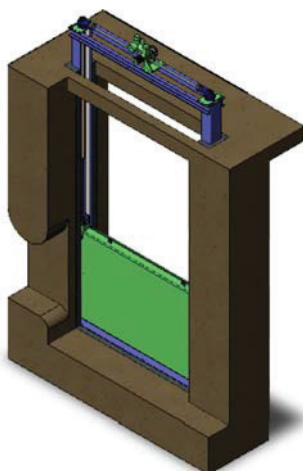
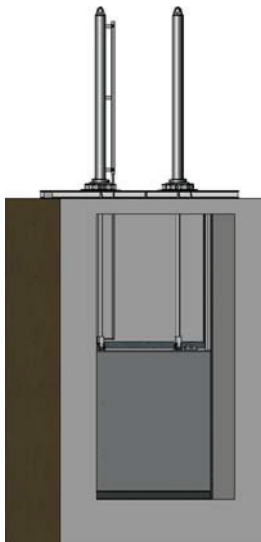
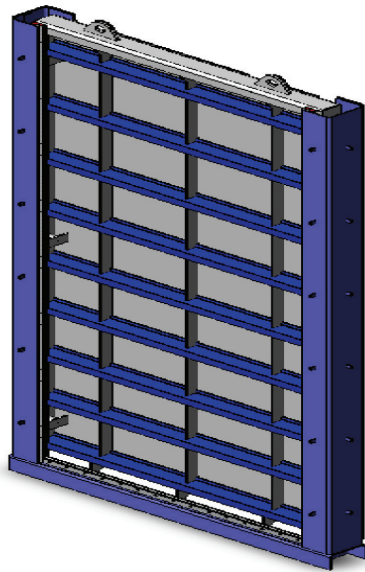



**VALVES
AND
DAMPERS
FOR
AIR & GASES**

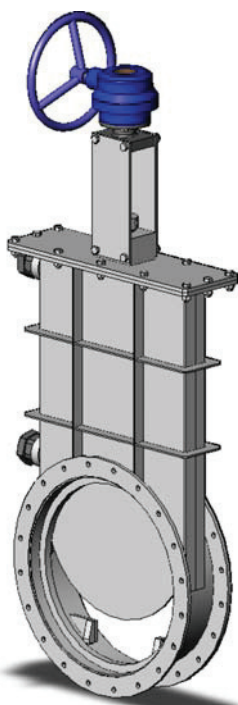

PRODUCT DESCRIPTION

Round Damper guillotine type GR manufactured by CMO is especially useful as an element of isolation to allow inspections, maintenance and repairs on the pipes.

The basic mechanical elements that make up the guillotine type of damper GR, is a rack or foreign body that contains a piece that moves inside lengthwise, a sealing peripheral to prevent leakage of gas in all phases of the movement of the knife of gate, necessary supports and an actuator

GENERAL APPLICATIONS

This damper knife gate valve is appropriate for a wide range of air & gases applicationsigned for a wide range of applications such as:

- Cement Plants
- Steel Plants
- Chemical plants.
- Power plants.
- ...



TECHNICAL DATA FOR GR SERIES

Standard manufacturing sizes:

From DN50 up to DN3000 (bigger sizes under request) GR Series
50x50 up to 3000x3000 (bigger sizes under request) GC Series
Also rectangular designs available

Working pressures:

From DN 50 to DN 2000: 0,5 (kg/cm2)
Higher pressures available under request

Flange connection drillings:

The standard flange connection is according to CMO design but any flange design and drill can be done

Applied Directives:

Directive 98/37/CE (machinery), Directive 97/23/CE (PED: Group 2),
Directive 94/9/CE (ATEX: Group II, Cat. 3 / Zones 2 and 22)

Tightness

From 98,5% to 99,5% Also available under request 100% tightness with double gate and air flushing system



PRODUCT DESCRIPTION

Square or Rectangular Damper guillotine type GR manufactured by CMO is especially useful as an element of isolation to allow inspections, maintenance and repairs on the pipes.

The basic mechanical elements that make up the guillotine type of damper GC, is a rack or foreign body that contains a piece that moves inside lengthwise, a sealing peripheral to prevent leakage of gas in all phases of the movement of the knife of gate, necessary supports and an actuator

GENERAL APPLICATIONS

This damper knife gate valve is appropriate for a wide range of air & gases applicationsigned for a wide range of applications such as:

- Cement Plants
- Steel Plants
- Chemical plants.
- Power plants.
- ...

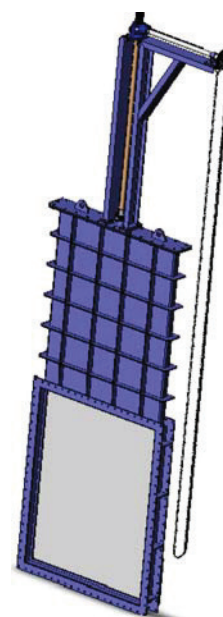

ACCESORIES FOR GR-GC SERIES

Mirror Polished Gate, Stellite gate, Scraper in the packing, Air injection in the packing gland, Flushing holes in body
Mechanical Limit Switches, Inductive Switches and Positioners
Solenoid valves, Connection electrical boxes, electrical wiring and pneumatic piping, Stroke limiting mechanical stops
Mechanical locking device

PRODUCT DESCRIPTION

Flanged light butterfly, square, rectangular louvered type, several blades.. Welded construction body and disc. Manufactured with different kinds of tightness depending the customer requirements (100% tight, 99,5% tight o 98,5% tight). Fabrication materials: S275JR carbon steel, H11 carbon steel, 16MO3 carbon steel, different stainless steel qualities (aisi 304, 316, 310 ...). Depending the application.

GENERAL APPLICATIONS

Pneumatic transports, exhaust gas control on chimneys, exhaust gas control on combustion processes, gas turbina exhaust gas control ...

Actuators: Manual, pneumatic, electric ... Working pressure: According to the standard manufacturing way these valves are designed to resist 0,25 kg/cm2 at ambient temperature.

- Cement Plants
- Steel Plants
- Chemical plants.
- Power plants.
- ...



TECHNICAL DATA FOR PL-UL SERIES

Standard manufacturing sizes:
From 400x400 up to 5000x5000 (bigger sizes under request)
Also rectangular designs available

Working pressures:
0,25 (kg/cm2)

Higher pressures available under request

Flange connection drillings:
The standard flange connection is according to CMO design but any flange design and drill can be done

Applied Directives:
Directive 98/37/CE (machinery), **Directive 97/23/CE (PED: Group 2)**,
Directive 94/9/CE (ATEX: Group II, Cat. 3 / Zones 2 and 22)

Tightness
From 97% to 99,5%



PRODUCT DESCRIPTION

Flanged light butterfly, square, rectangular single blade. Welded construction body and disc. Manufactured with different kinds of tightness depending the customer requirements (100% tight, 99,5% tight o 98,5% tight). Fabrication materials: S275JR carbon steel, H11 carbon steel, 16MO3 carbon steel, different stainless steel qualities (aisi 304, 316, 310 ...). Depending the application.

GENERAL APPLICATIONS

Pneumatic transports, exhaust gas control on chimneys, exhaust gas control on combustion processes, gas turbina exhaust gas control ...

Actuators: Manual, pneumatic, electric ... Working pressure: According to the standard manufacturing way these valves are designed to resist 0,25 kg/cm2 at ambient temperature.

- Cement Plants
- Steel Plants
- Chemical plants.
- Power plants.
- ...



ACCESORIES FOR PL-UL SERIES

Mirror Polished Gate, Stellite gate, Air injection in the packing gland, Flushing holes in body
Mechanical Limit Switches, Inductive Switches and Positioners
Solenoid valves, Connection electrical boxes, electrical wiring and pneumatic piping, Stroke limiting mechanical stops
Mechanical locking device

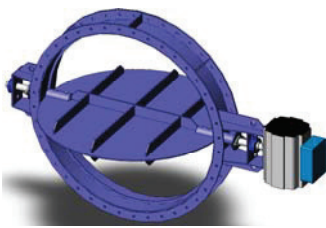

PRODUCT DESCRIPTION

Flanged or wafer butterfly damper valve. Cast or welded body and disc depending the diameter of the valve. Manufactured with different kinds of tightness depending the customer requirements (100% tight, 99,5% tight o 98,5% tight). Fabrication materials: S275JR carbon steel, H11 carbon steel, 16MO3 carbon steel, different stainless steel qualities (aisi 304, 316, 310 ...). Depending the application.

GENERAL APPLICATIONS

Pneumatic transports, exhaust gas control on chimneys, exhaust gas control on combustion processes, gas turbina exhaust gas control ...

Actuators: Manual, pneumatic, electric ... Working pressure: According to the standard manufacturing way these valves are designed to resist 0,5 kg/cm2 at ambient temperature.

- Cement Plants
- Steel Plants
- Chemical plants.
- Power plants.
- ...

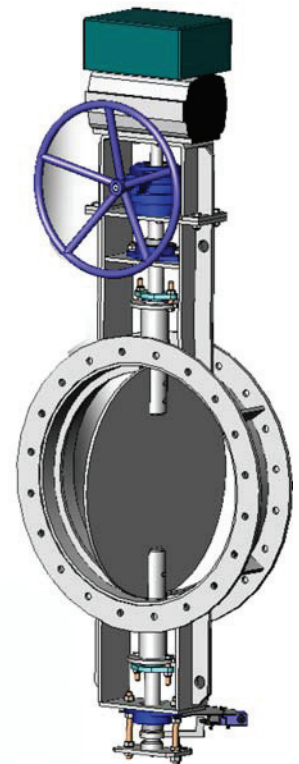
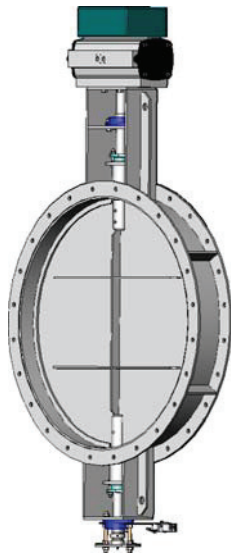

TECHNICAL DATA FOR MF-LR SERIES

Standard manufacturing sizes:

From DN50 up to DN3000 (bigger sizes under request) MF Series
Also rectangular designs available

Working pressures:

From DN 50 to DN 2000: 0,5 (kg/cm2)
Higher pressures available under request

Flange connection drillings:

The standard flange connection is according to CMO design but any flange design and drill can be done

Applied Directives:

Directive 98/37/CE (machinery), **Directive 97/23/CE (PED: Group 2)**,
Directive 94/9/CE (ATEX: Group II, Cat. 3 / Zones 2 and 22)

Tightness

From 97% to 99,5% Also available under request 100% tightness with double gate and air flushing system

PRODUCT DESCRIPTION

Flanged or wafer butterfly damper valve. This valve is equal to the type MF with the difference that instead of one disc the valve is composed by several blades. The valve is manufactured with welded construction. Manufactured with different kinds of tightness depending the customer requirements (100% tight, 99,5% tight o 98,5% tight). Fabrication materials: S275JR carbon steel, H11 carbon steel, 16MO3 carbon steel, different stainless steel qualities (aisi 304, 316, 310 ...). Depending the application.

GENERAL APPLICATIONS

Pneumatic transports, exhaust gas control on chimneys, exhaust gas control on combustion processes, gas turbina exhaust gas control ...

Actuators: Manual, pneumatic, electric ... Working pressure: According to the standard manufacturing way these valves are designed to resist 0,5 kg/cm2 at ambient temperature.

- Cement Plants
- Steel Plants
- Chemical plants.
- Power plants.
- ...

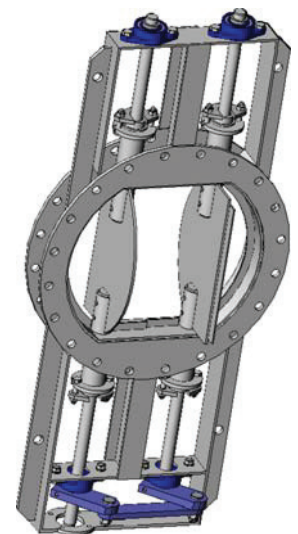
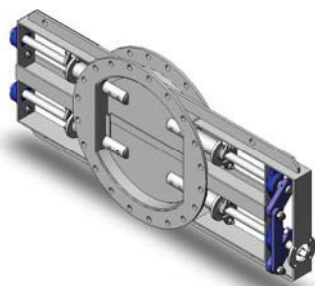

ACCESORIES FOR MF-LR SERIES

Mirror Polished Gate, Stellite gate, Scraper in the packing, Air injection in the packing gland, Flushing holes in body
Mechanical Limit Switches, Inductive Switches and Positioners
Solenoid valves, Connection electrical boxes, electrical wiring and pneumatic piping, Stroke limiting mechanical stops
Mechanical locking device



SC SERIES SPECIAL

PRODUCT DESCRIPTION

Specially designed to be mounted in installations for transport of solids of fine grain as cement, ash, sand, etc. In all type of industry with pneumatic transport, by pipes with flanges or in inlets and outlets of silos. The normal in this kind of work where the standard pressures are from 0 to 2kg/cm². Other pressures to be discussed.

Construction: Body in cast iron, steel, stainless steel, etc. Seat: metal/metal - Aisi 304 + stellite metal/rubber - Aisi 304 + EPDM Shafts: Aisi 304 Tightness to the outside, depending on the temperature and working conditions.

Temperature: from -10 to +90°C

Drivers: Manual, pneumatic, electric, etc.



SD SERIES



TECHNICAL DATA FOR SD-SP-SC SERIES

Standard manufacturing sizes:
From DN 50 up to DN 600 (bigger sizes under request)

Working pressures: 1 (kg/cm²)
Higher pressures available under request

Flange connection drillings:
The standard flange connection is according to CMO design but any flange design and drill can be done

Applied Directives:
Directive 98/37/CE (machinery), **Directive 97/23/CE (PED: Group 2)**, Directive 94/9/CE (ATEX: Group II, Cat. 3 / Zones 2 and 22)

Tightness 100%

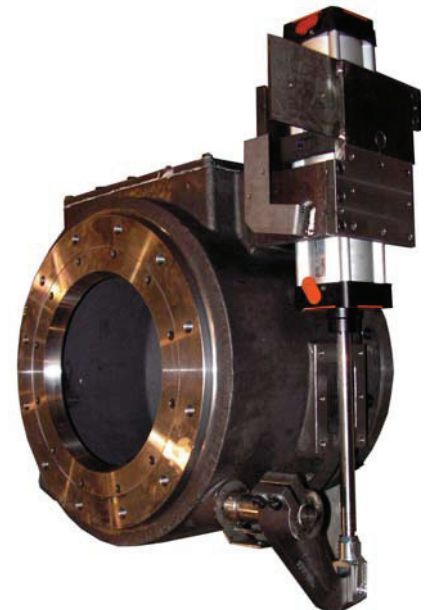

SD SERIES

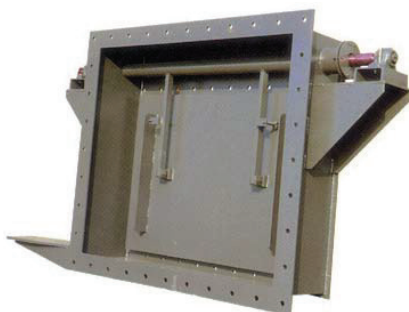

SC SERIES



SP SERIES FOR CEMENT

PRODUCT DESCRIPTION

Round-port isolating valve actuated by a three-lever system that rotates the disc through 90°.

Rugged fabricated construction can withstand pressures up to 40 bar, depending on dimensions, and temperatures up to 500°C.

Various sealing systems available to provide up to 100% tightness.

Available with pneumatic, electric or hydraulic actuator.

This is a valve which, due to its mechanical system of movement, offers several advantages compared to other butterfly valves. These advantages include the elimination of friction between the disc and the seat thus lengthening the valve's service life.

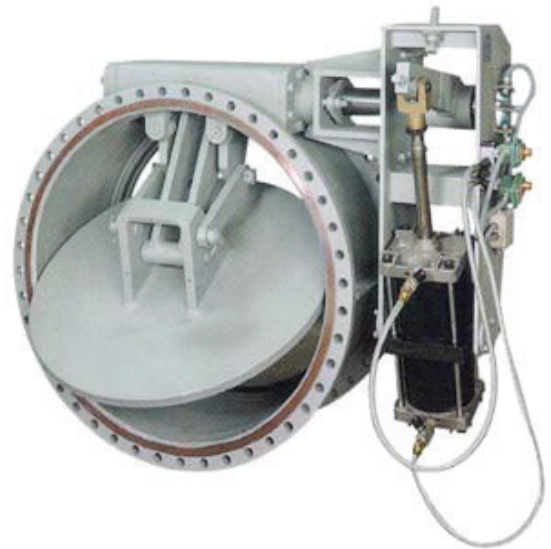

APPLICATION

The MP model is a general-purpose, uni-directional flanged valve for gaseous clean fluids such as atmospheric air, nitrogen, oxygen etc. and gaseous dirty fluids carrying suspended solids.

For the latter application the valve has a register for both the build-up of solids and cleaning.

Sizes: up to DN 3000

