

USERS MANUAL

Balancing valve

Fig. 447

Edition: 10/2010

Date: 15.10.2010

CONTENTS

1. Product description
2. Requirements for maintenance staff
3. Transport and storage
4. Function
5. Application
6. Assembly
7. Maintenance
8. Service and repair
9. Adjustment of valve
10. Additional equipment of valves
11. Reasons of operating disturbances and remedy
12. Valve service discontinuity
13. Warranty terms



1. PRODUCT DESCRIPTION

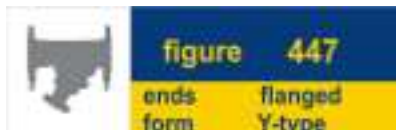

Balancing valves Fig. 447 are used for medium flow control. Medium flows according to arrow direction indicated on the valve.

Balancing valves are provided with casted marking according to requirements of PN-EN19 standard. The marking facilitates technical identification and contains :

- diameter nominal DN (mm),
- pressure nominal PN (bar),
- body and bonnet material marking,
- arrow indicating medium flow direction,
- manufacturer marking,
- heat number,
- CE marking, for valves subjected to 97/23/EC directive. CE marking starts from DN32.

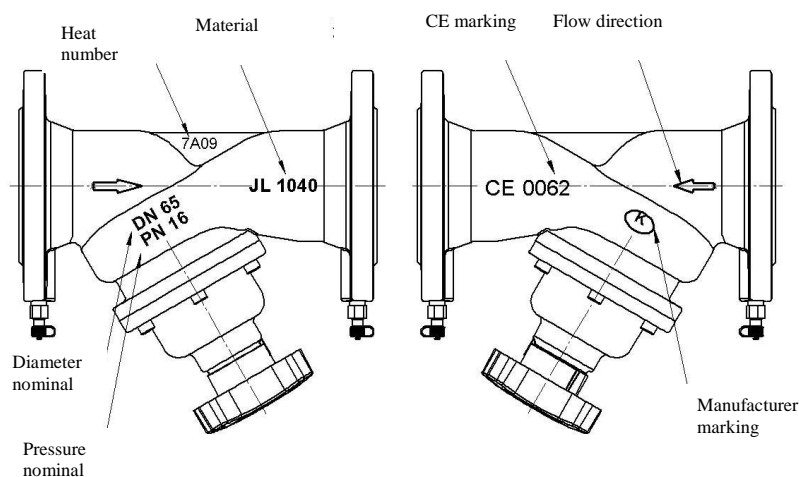

2. REQUIREMENTS FOR MAINTENANCE STAFF

The staff assigned to assembly, operating and maintenance tasks should be qualified to carry out such jobs. During valve operation heat parts of the valve, for example handwheel, body or bonnet parts could cause burn. If necessary the user should fit insulation shields and warning boards.

3. TRANSPORT AND STORAGE

Transport and storage should be carried out at temperature from -20° to 65°C , and valves should be protected against external forces influence and destruction of painting layer as well. The aim of painting layer is to protect the valves against rust during transport and storage. Valves should be kept at unpolluted rooms and they should be also protected against influence of atmospheric conditions. There should be applied drying agent or heating at damp rooms in order to prevent condensate formation. The valves should be transported in such a way to avoid handwheel and valve stem damage.

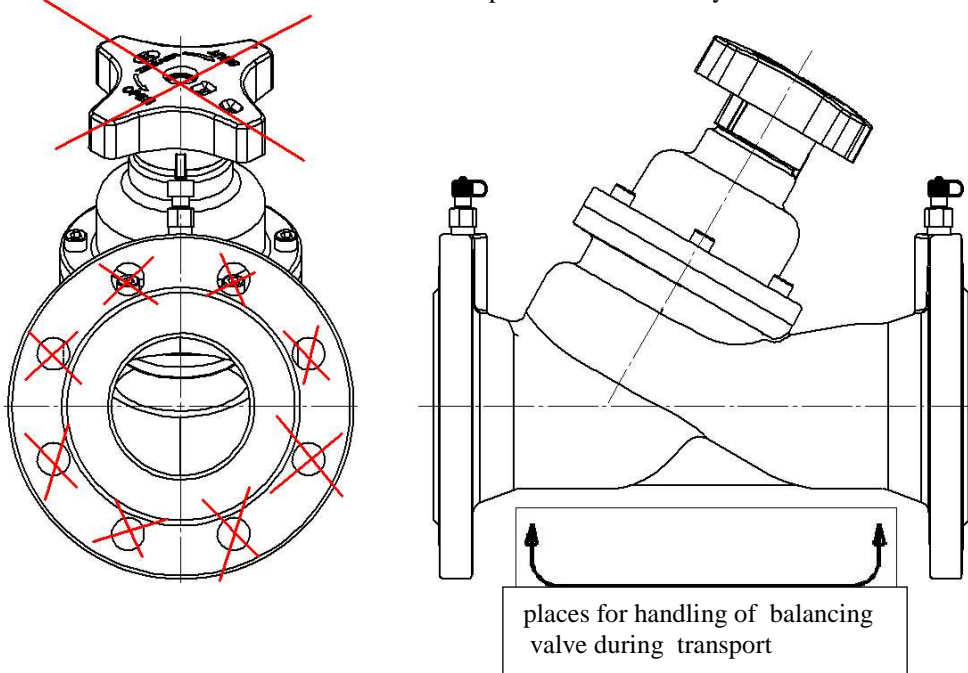

It is not allowed to fit lifting devices to connecting holes and handwheels.

4. FUNKTION

Balancing valves are designed to control hydraulic flow at HVAC plants. The valves can be put into feeding and return pipelines as well.

Application range was mentioned at catalogue card. The kind of working medium makes some materials to be use or to be prohibited for use. Valves were designed for normal working conditions. In the case that working conditions exceed these requirements (for example for aggressive or abrasive medium) user should ask manufacturer before placing an order.

When selecting the valve for specific medium, "List of Chemical Resistance" can be helpful. It can be found at manufacturer website near catalogue cards.

Working pressure should be adapted to maximum medium temperature according to the table as below.

Balancing valves Fig. 447

Wg EN 1092-2		Temp. [$^{\circ}\text{C}$]
Material	PN	-10 do 120
EN-GJL250	16	16 bar



Plant designer is responsible for valve selection suitable for working conditions.

5. APPLICATION

- heat water, cooling water and glycol plants
- heating, chilling, industrial air conditioning

6. ASSEMBLY

During the assembly of balancing valves following rules should be observed:

- to evaluate before an assembly if the valves were not damaged during the transport or storage and to make sure that applied valves are suitable for working conditions and medium used in the plant,
- to take off dust caps if the valves are provided with them,

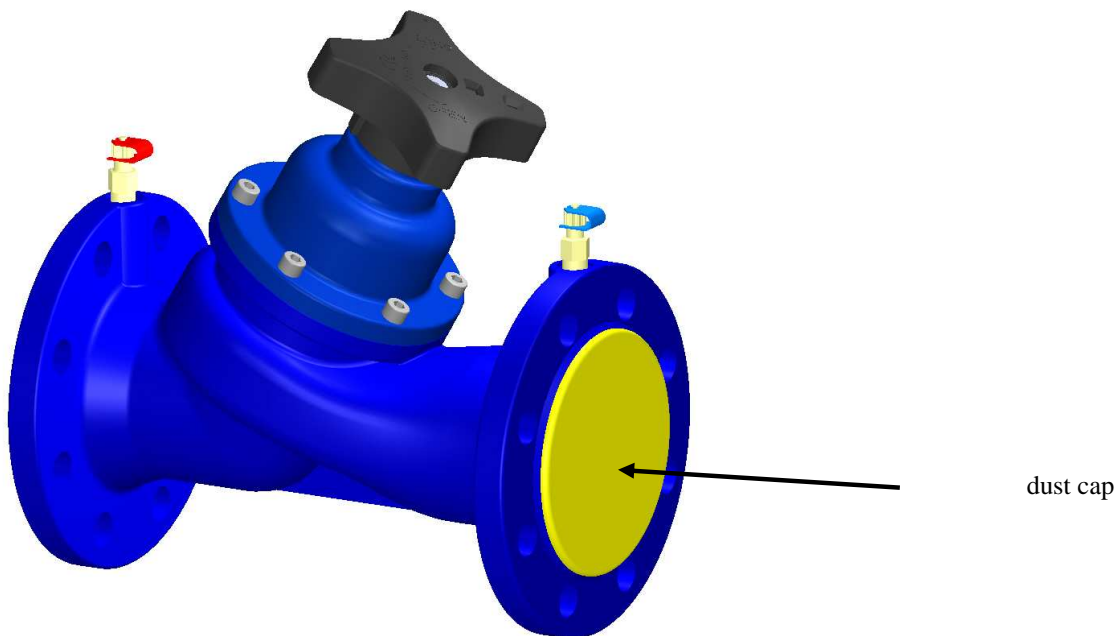

- to check if the valve interior is free of foreign bodies,
- to protect the valves during welding jobs against splinters and to use plastics against excessive temperature,

⚠ Pipeline where the valves are fitted should be conducted and assembled in such a way that the valve body is not subjected to bending moment and stretching forces.

Bolted joints on the pipeline must not cause additional stress resulted from excessive tightening, and fastener materials must comply with working conditions of the plant.

- to apply expansion pipe joints in order to reduce influence of pipeline thermal expansion,

⚠ To assembly the valve in such a way that flow direction comply with an arrow placed on the body,

- correct acting of the valve requires suitably long straight pipelines: 5 x DN before the valve and 2 x DN after it
- during painting of pipeline the valve stem, and plastic parts as well as vernier pitch should be protected ,
- valves can be assembled in any position, however it is recommended to install the valve with handwheel downwards,
- before plant startup, especially after repairs carried out, flush out the pipelines through entirely open valves
- strainer (wire mesh filter) installed before the valve increases certainty of its correct action.

7. MAINTENANCE

During maintenance following rules should be observed:

- startup process – sudden changes of pressure and temperature should be avoided when starting the plant,
- valve is closed by turning the handwheel clockwise when looking from above the handwheel (according to arrow direction marked on the handwheel),
- valve is opened by turning the handwheel counter-clockwise.

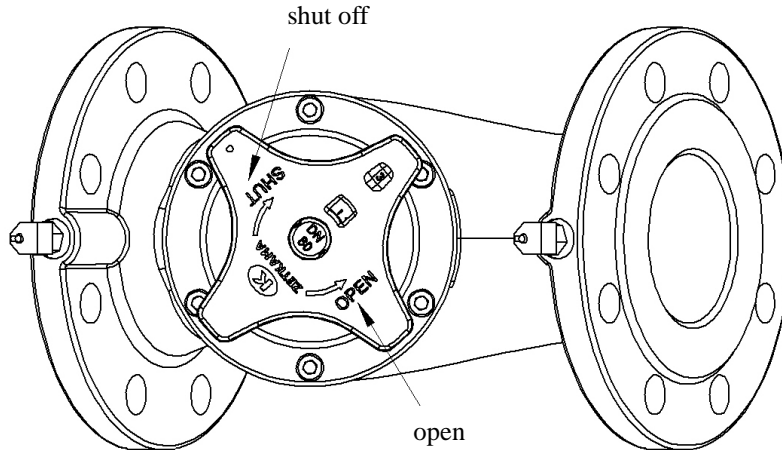

When closing does not exceed a value of “0” on the scale



It is prohibited to use additional lever when turning the handwheel
performance of fitted valves can be checked by multiple closing and opening



In order to assure safety performance, each valve (especially rarely used) should be surveyed on regular basis. Inspection frequency should be laid down by user, but not less than one time per month.

8. SERVICE AND REPAIR

Balancing Valves Figure 447 does not require maintenance, provided that they are used for its intended purpose.



Before taking up any service jobs it is necessary to make sure, if medium supply to the pipeline was shut off, if the pressure was decreased up to atmospheric pressure, if the medium was removed and plant cooled down.

- All service and repair jobs should be carried out by authorized staff using suitable tools and original spare parts.
 - Before disassembly of complete valve from the pipeline or before service, the pipeline should be out of operation.
 - During service and repair jobs it is necessary to use personal health protectives in pursuance of existing threat.
 - After valve disassembly it is necessary to replace flange connection gaskets between valve and pipeline .
 - Everytime when valve bonnet was disassembled sealing surface should be cleaned. During assembly it should be applied new gasket of the same type as previously used.
 - Body-bonnet bolt connections should be tighten when the valve is at open position,
 - The bolts should be tighten evenly and crosswise by torque wrench.
- before valves re-assembly in the pipeline it is necessary to check valve operation and tightness of all connections. Tightness test should be carried out with water pressure of 1,5 nominal pressure of the valve.

9. VALVE ADJUSTMENT FOR Fig. 447

The valve opening degree can be read on the dial



Number of turns between the locations closing and fully open is:

- 8 - DN 65 and 80
- 8.5 - for 100.125 and 150 DN
- 11 - DN 200.250 and 300

Set the valve on the 3.5 is done as follows:

1. Remove the wheel cap
2. Close the valve completely and check the scale of 0-0.
3. Open the valve to position 3.5 on the market.
4. Screw allen key screw located in the stem until it stops.
5. Replace the wheel cap

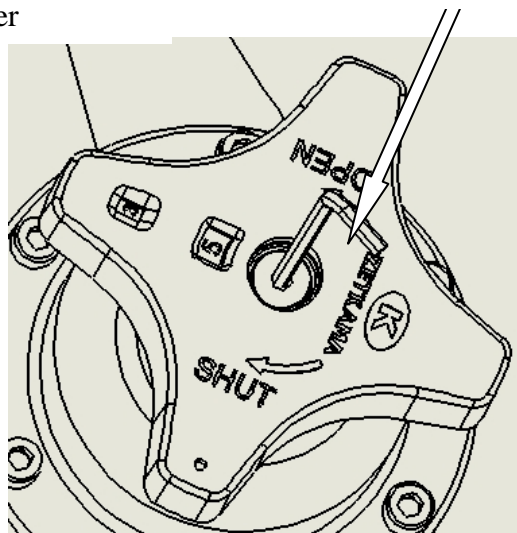

- For a proper setting of the valve position should be used tabulation of the characteristics of the valve and charts drawn up for each size of valve,

So adjusted balancing valve can be closed many times now, but it can be open up to adjusted value only .

Kv values for specific adjustment of Fig. 447:

n	DN65	DN80	DN100	DN125	DN150	DN200	DN250	DN300
	Kv [m ³ /h]							
0,5	3,6	5,9	5,6	8,3	7,9	27,5	43,5	44,9
1	5,2	8,0	9,6	13,0	14,8	38,6	62,3	57,1
2	9,3	11,8	16,6	23,7	29,7	54,6	87,3	89,8
3	14,8	16,7	34,0	51,2	83,7	99,9	163,9	140,7
4	27,2	31,2	71,4	106,5	183,7	216,2	345,3	331,7
5	48,2	65,0	107,4	160,9	247,1	341,2	543,3	634,1
6	65,0	89,3	135,0	201,9	298,2	430,1	694,0	825,1
7	75,1	102,7	159,9	239,8	342,2	507,6	823,7	1017,8
8	85,2	113,4	177,9	270,8	376,8	560,8	925,3	1169,7
8,5			184,7	285,1	390,2			
9						619,3	1022,4	1285,1
10						667,2	1110,2	1394,1
						710,0	1187,5	1504,1

n – number of handwheel turns

10. ADDITIONAL EQUIPMENT OF VALVES.

The valves are provided with threaded holes G 1/4" on each flange, with plugs screwed in as standard. On customer request the plugs can be replaced with measuring nipples.

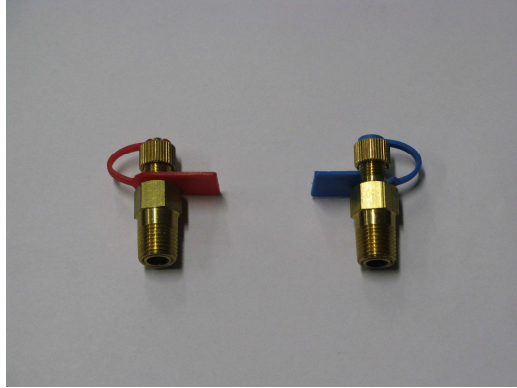

Digital measuring computer can be used to take the measurements. Flow values of ZETKAMA's balancing valves are stored in its memory, so direct flow measurement is possible. The computer enables pressure or temperature drop measurement and recording possibilities. Detailed description of this device is included at catalogue card of computer manufacturer.



11. REASONS OF OPERATING DISTURBANCES AND REMEDY

- When seeking of valve malfunction reasons safety rules should be strictly obeyed

Fault	Possible reason	Remedy
No flow	Valve closed	Open the valve
	Flange dust caps were not removed	Remove dust caps on the flanges
Poor flow	Valve is not open enough	Open the valve
	Dirty filter	Clean or replace the screen
	Clogged pipeline	Check the pipeline
Control difficulties	Dry stem	Grease the stem
	Gland packing tighten too much (ref. to Fig.443)	Slightly slacken gland nuts. Put attention to keep stuffing box tightness.
Stem leakage	Too much loose on the gland (ref. to Fig. 443)	Tighten the gland untill tightness will be reached If necessary add packing rings in stuffing box. Keep special caution.
	Damaged O-rings (ref. to Fig. 445)	Replace O-rings
Seat leakage	Shut off not correct	Tighten the handwheel without any auxiliary tools.

	Seat or disc damage	Replace the valve and contact supplier or manufacturer
	Pressure difference too much	Check if the valve was assembled according to arrow direction marked on the valve.
	Medium polluted with solid particles	Clean the valve. Fit strainer before the valve.
Broken connecting flange	Bolts tighten unevenly	Replace the valve with new one

12. VALVE SERVICE DISCONTINUITY

All obsolete and dismantled valves must not be disposed with household waste. ZETKAMA valves are made of materials which can be re-used and should be delivered to designated recycling centres.

13. WARRANTY TERMS

- ZETKAMA grants quality warranty with assurance for proper operation of its products, providing that assembly of them is done according to the users manual and they are operated according to technical conditions and parameters described in ZETKAMA's catalogue cards. Warranty period is 18 months starting from assembly date, however not longer than 24 months from the sales date.
- warranty claim does not cover assembly of foreign parts and design changes done by user as well as natural wear.
- immediately after detection the user should inform ZETKAMA about hidden defects of the product
- a claim should be prepared in written form.

Address for correspondence :

ZETKAMA Spółka Akcyjna
 ul. 3 Maja12 57-410 Ścinawka Średnia
 Telefon (0048) (74) 8652100
 Telefax (0048) (74) 8652101
 Internet: [http:// www.zetkama.com.pl](http://www.zetkama.com.pl)