

**INSTALLATION AND MAINTENANCE INSTRUCTIONS  
FOR KLINGER LEVEL GAUGE VALVES  
DVK-2 IT****VALVES TYPE DVK-2 IT**  
FOR LEVEL GAUGES:

- TA 120
- T 85
- A400

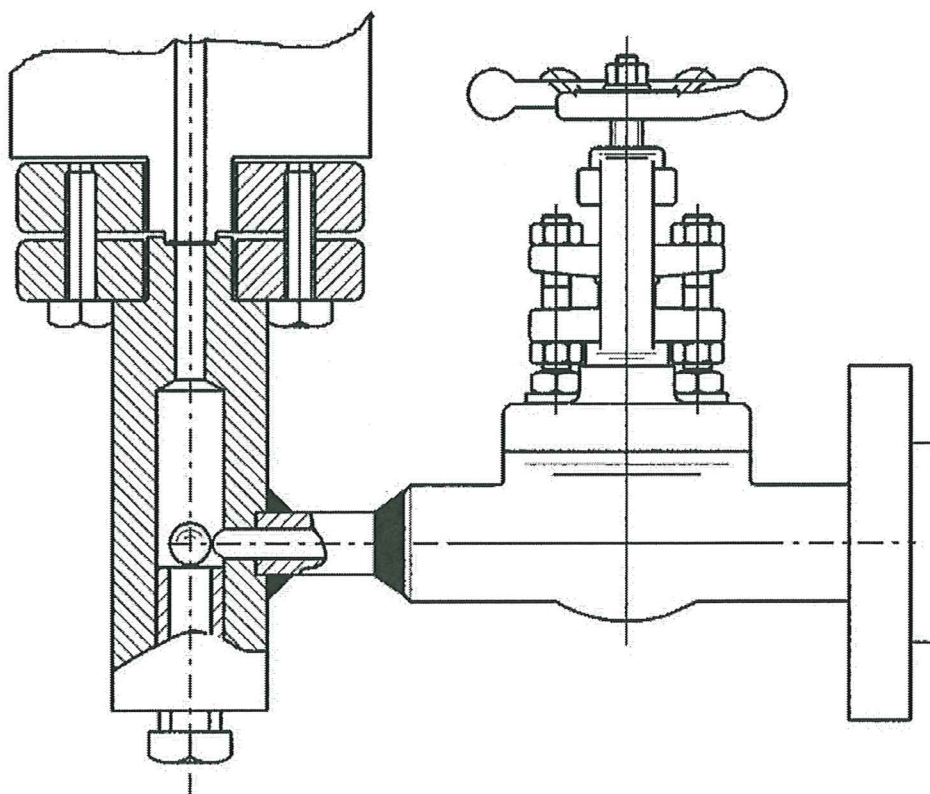

**INSTALLATION AND MAINTENANCE INSTRUCTIONS  
FOR KLINGER LEVEL GAUGE VALVES  
DVK-2 IT****INSTALLATION AND MAINTENANCE INSTRUCTIONS  
FOR KLINGER LEVEL GAUGE VALVES DVK-2 IT****1. GENERALITY AN OPERATING PRINCIPLE**

Klinger level gauge valves type DVK-2 IT are globe type valves.

They are intended specially for use on steam gauges.

Above all, these valves are notable for their excellent seal to atmosphere and are almost maintenance-free.

DVK-2 IT gauge valves are of forged steel construction with metal-to-metal sealing through seats, the hardened ground piston and the soft stainless seat providing an outstanding seal through the valve. A stuffing box and a metallic gasket between body and bonnet provide a reliable seal to atmosphere.

A safety ball is provided in the upper and lower connection piece so that escape of steam or hot water in the event of a glass breakage is largely prevented.

**2. INSTALLATION**

- 2.1 DVK-2 IT valves must be installed when the line is completely without pressure and boiler shut down
- 2.2 Remove ends protections only at the last moment before installation.
- 2.3 Check nameplates to make sure of type and class of valve.
- 2.4 Check internal parts of end connections and pipe to avoid any presence of impurity.
- 2.5 Operate valve (open and close) to make sure no damage has occurred during transport or store.
- 2.6 Lubricate stem thread with proper grease.

**INSTALLATION AND MAINTENANCE INSTRUCTIONS  
 FOR KLINGER LEVEL GAUGE VALVES  
 DVK-2 IT**

**INSTALLATION INSTRUCTIONS**

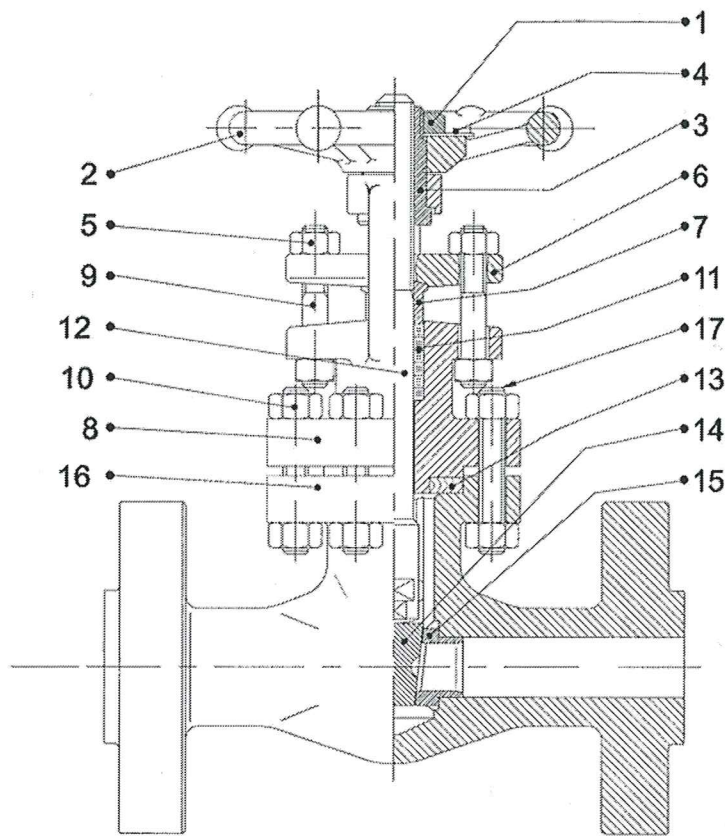

- 1 Nut
- 2 Handwheel
- 3 Yoke Sleeve
- 4 Name Plate
- 5 Gland Nuts
- 6 Gland Flange
- 7 Packing Gland
- 8 Bonnet
- 9 Gland Studs
- 10 Nuts
- 11 Packing
- 12 Stem

- 13 Gasket
- 14 Wedge
- 15 Seat Ring
- 16 Body
- 17 Studs

**INSTALLATION AND MAINTENANCE INSTRUCTIONS  
FOR KLINGER LEVEL GAUGE VALVES  
DVK-2 IT****3. DISMANTLING**

3.1 When dismantling, the body of the gauge valve need to be disconnected from the boiler connecting flange. However, the boiler must be shut down, unless a reserve shut-off valve is present.

**4. TIGHTENING OF GLAND BOLTING**

Special care is to be placed in the tightening of gland nuts during installation or after replacement of the packing or during periodic checks (remember that due the natural loss of elasticity of the packing during time tightening might turn necessary). During tightening check that stuffing box flange, subject to movements caused by the operator, does not lead to horizontal or rotary shifting with respect to the lid flange. So proceed to lock in a reciprocating way (one an then the other) checking that the stuffing box flange remains parallel to the lid flange.

Furthermore check that tightening is enough to guarantee no leakages and a good handling in opening and closing the valve

If locking is excessive to guarantee the *a.m.* handling, unscrew step by step the boltings till result is satisfactory, keeping under control that no leakages must arise from packing area.

If some leaks arise, the packing must be replaced again and all steps repeated.

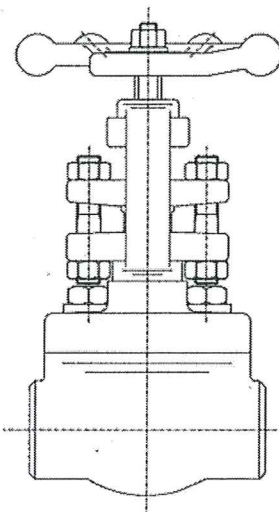
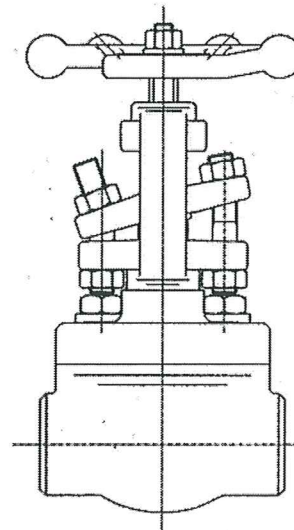
**YES****NO**

**INSTALLATION AND MAINTENANCE INSTRUCTIONS  
FOR KLINGER LEVEL GAUGE VALVES  
DVK-2 IT****5. BODY BONNET BOLTINGS**

Only proceed to this operation changing one bolt at a time to prevent losses of pressure on the gasket.

**6. REPLACEMENT OF THE GASKET**

Replacement of gasket is possible only without pressure on line. Replace the body-bonnet gasket locking bolts in a crossed way (see figure).

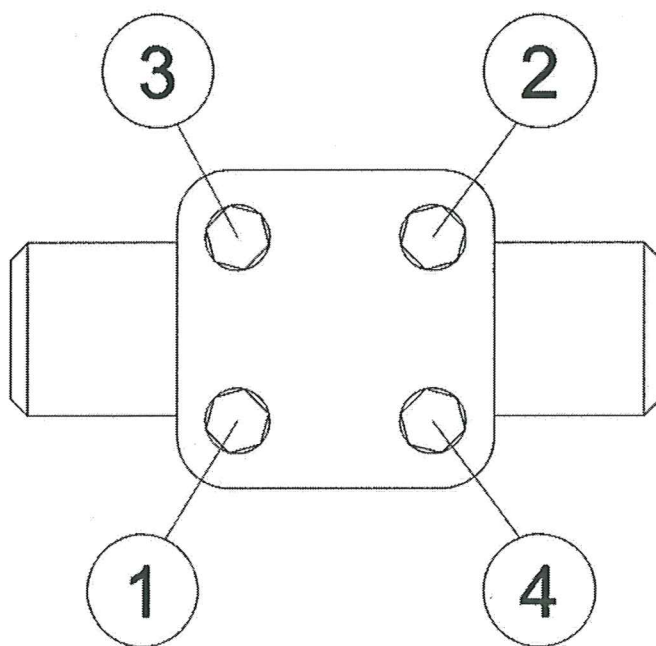



**INSTALLATION AND MAINTENANCE INSTRUCTIONS  
FOR KLINGER LEVEL GAUGE VALVES  
DVK-2 IT****7. REPLACEMENT OF PACKING**

7.1 Replacement not in service (see para 8.2: replacement of stem).

7.2 Replacement with valve in service. Note: the maximum care must be used being a hazardous operation.

- a) Proceed opening completely the valve taking care that the stem is brought back to beakseat position.
- b) Only when the stem is in this position, loosen the bolts of the stuffing box flange to remove pressure from the packing pack.
- c) Check that the stem is really in the beakseat position ensuring that there are no losses.
- d) Only at this point release completely the nuts and move the flange and the packing gland ring upwards. Remove packing and replace with the new one.
- e) Bring the packing gland ring and the flange to the original position.
- f) Tighten the gland boltings as described in point 4.0.

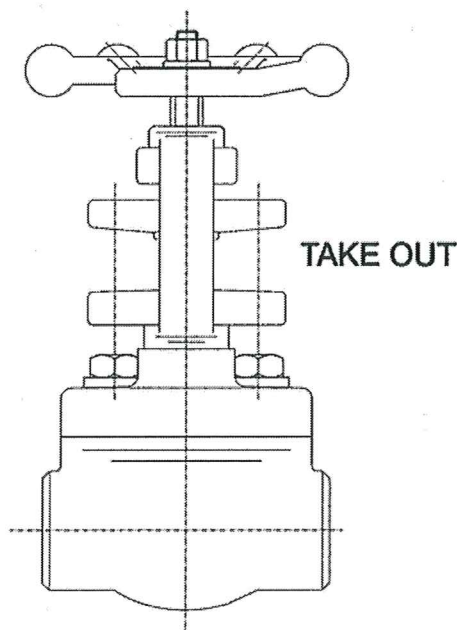

**INSTALLATION AND MAINTENANCE INSTRUCTIONS  
FOR KLINGER LEVEL GAUGE VALVES  
DVK-2 IT****8. MAINTENANCE ON DISC, STEM AND SEAT ON GLOBE VALVES BOLTED BONNET.****8.1 DISC**

- a) Proceed opening completely the valve taking care that the stem is brought back to beackseat position.
- b) Loosen body-bonnet bolting.
- c) Remove bonnet with stem and disc attached.
- d) Replace the disc, removing the handwheel and turning it in clockwise direction so that can leave the bonnet. Assemble the new one in anticlockwise direction to the bonnet and put again the handwheel in the original position.
- e) Replace the body-bonnet gasket.
- f) Reassembly the group bonnet-stem-disc and close bolts.

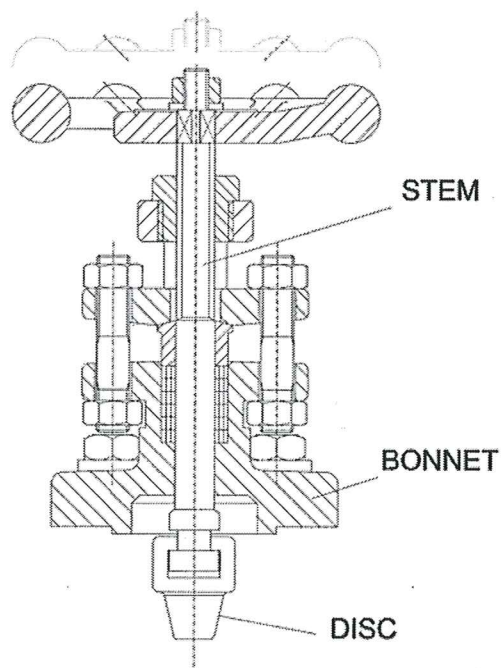

**INSTALLATION AND MAINTENANCE INSTRUCTIONS  
FOR KLINGER LEVEL GAUGE VALVES  
DVK-2 IT****8.2 STEM**

- a) Proceed opening completely the valve taking care that the stem is brought back to backseat position.
- b) Loosen body-bonnet bolting.
- c) Remove bonnet with stem.
- d) Make sure that surfaces of the stem (especially the ones in contact with packing) are not damaged. Replace the new stem-disc group screwing it anticlockwise in the bonnet yoke sleeve.
- e) Replace body-bonnet gasket.
- f) Reassembly the group bonnet-stem-disc and close bolts.

**8.3 SEAT**

- a) Proceed opening completely the valve taking care that the stem is brought back to backseat position.
- b) Loosen body-bonnet bolting.
- c) Remove bonnet with stem and disc attached.
- d) Check that no damages there are on the seat. Replace the new seat removing the old one turning it in anticlockwise way with a proper hexagon ring wrench so that it can leave the body. Assemble the new one in clockwise way to the body.
- e) Replace the body-bonnet gasket.
- f) Reassembly the group bonnet-stem-disc and close bolts.



**INSTALLATION AND MAINTENANCE INSTRUCTIONS  
FOR KLINGER LEVEL GAUGE VALVES  
DVK-2 IT****9. STORE INSTRUCTION**

- 1) Store the goods enclosed rooms in dry place in a non aggressive atmosphere and protected against dampness and dirt in order to avoid the oxidation of metallic elements.
- 2) Protect the goods against pushes in order to avoid the breakage of the glass.

**IMPORTANT NOTE:  
LONG STORAGE**

The package and the valve have to be periodically checked during long storage ( at least every three months ), to verify its integrity, keeping suitable documentation of above activities.