

B100 Series OV

Pressure & Vacuum Relief Valves

Product Highlights

- Open vent Weight Loaded
- Standard Pressure settings + 2 mbarg to 100 mbarg
- Standard Vacuum settings - 2 mbarg to - 100 mbarg
- Size range 2" (50 mm) - 12" (300 mm)
- Standard body materials - Aluminium, Carbon steel, Stainless steel
- Standard trim material - Stainless steel
- Diaphragm material - PTFE
- Removable seats
- Standard full form flanges - ANSI / DIN / JIS / Specials
- Lightweight design
- Steam Jackets
- Proximity Switches to indicate pallet lift
- Tri clamp / screwed connections available
- Alternative materials for hazardous applications
- Non standard applications consult factory

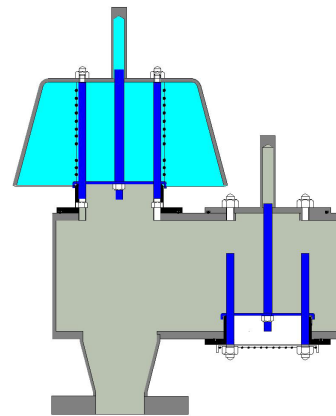

B100 OV

Features

Low cost maintenance

Lightweight design provides easy handling whilst interchangeable components ensure standard parts are easily replaced

Testing / Quality

All products are factory tested and fully certified.

Self Draining

All products are designed so that any condensate drains away from seating areas.

Low leakage

Standard seating design ensures minimum leakage of less than 1 scfh at 90% of set pressure.

Internal Parts

Internal parts are stainless steel as standard. Non standard materials available upon request.

Connections

All valves are supplied with full form flanges to meet individual requirements. Other connections are available upon request.

Non Standard Applications

There are numerous options available for special applications. Exotic materials such as Hastelloy and various plastics can be offered to suit the most hazardous of environments. Special coatings can be applied for extreme service. For low temperature duties, internal parts can be PTFE coated to prevent seizure.

See separate section in catalogue.

* All products are subject to continuous development and subsequently 3B Controls reserve the right to change specifications outlined in this catalogue without notification.

B100 Series OV

Pressure & Vacuum Relief Valves

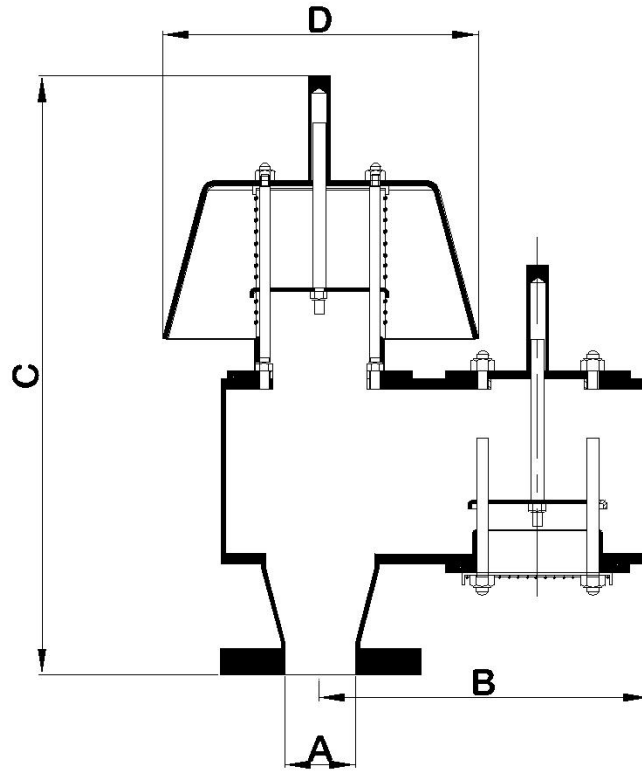

Dimensions

	A	B	C	D
50(2")	54	252	440	208
80(3")	64	308	515	305
100(4")	108	355	623	380
150(6")	161	516	721	535
200(8")	211	576	677	600
250(10")	255	701	750	650
300(12")	305	741	835	700

B100 Series OV Pressure & Vacuum Relief Valves

2" B100 OV Pressure Flow

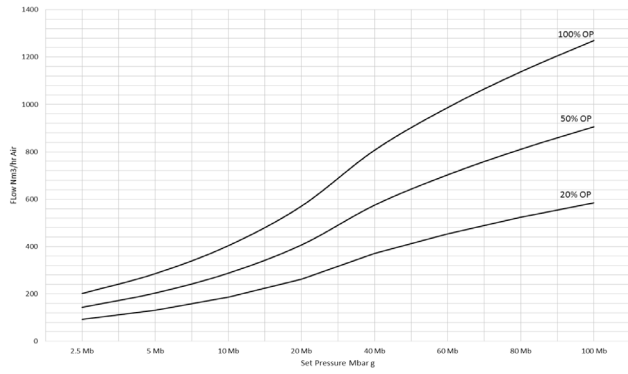

2" B100 OV Vacuum Flow

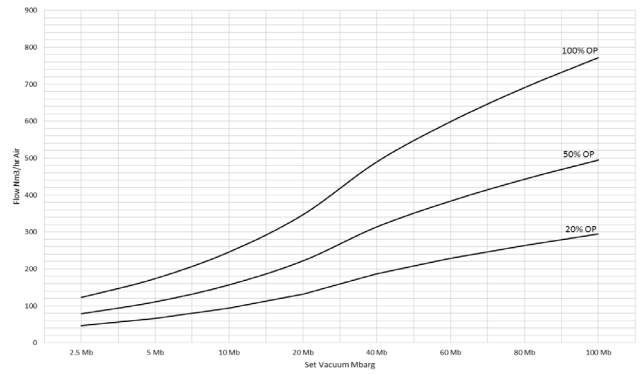

3" B100 OV Pressure Flow

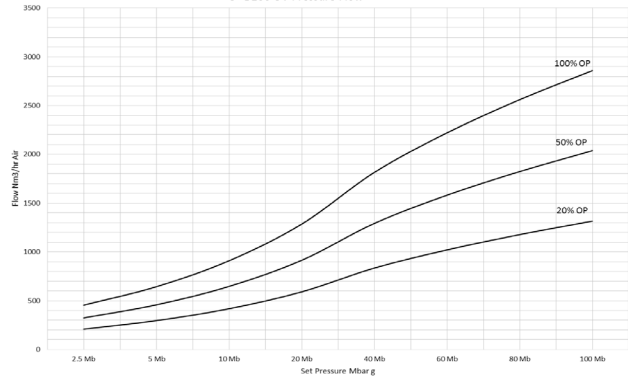

3" B100 OV Vacuum Flow

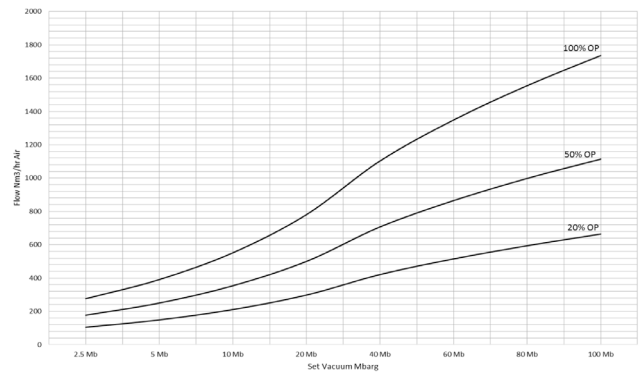

4" B100 OV Pressure Flow

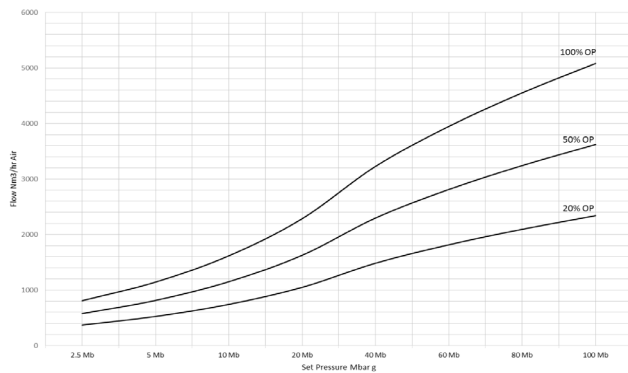

4" B100 OV Vacuum Flow

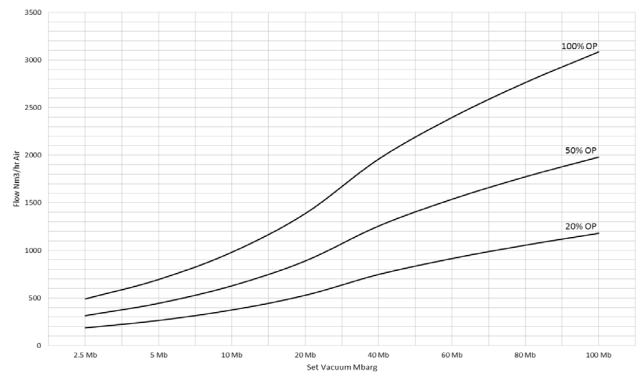

B100 Series OV

Pressure & Vacuum Relief Valves

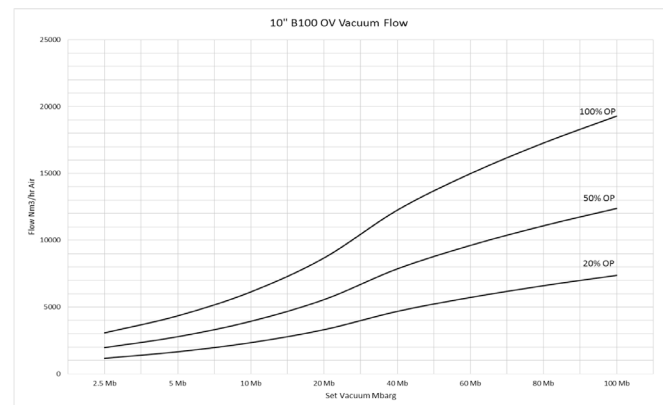
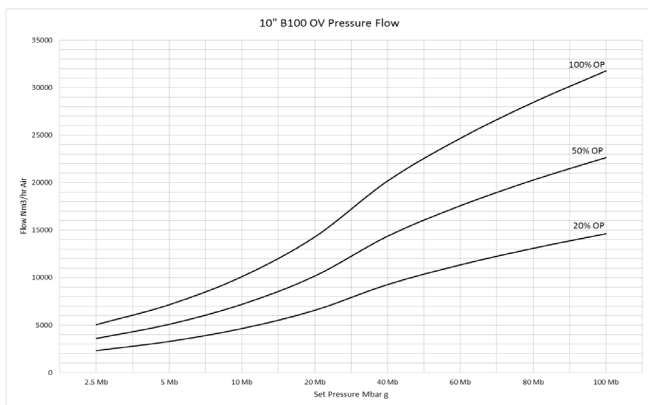
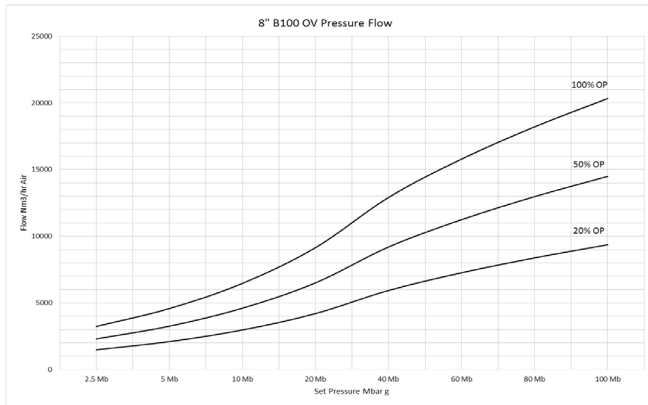
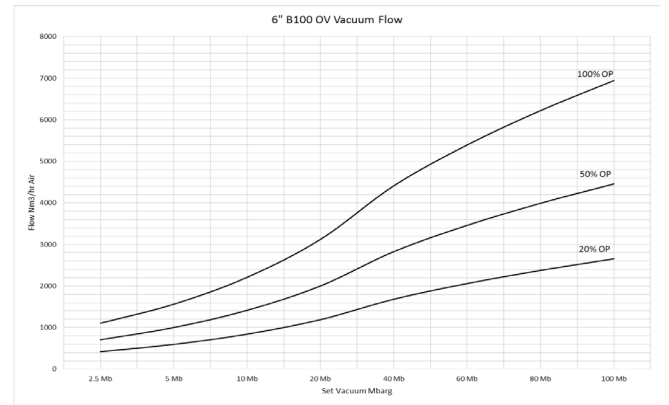
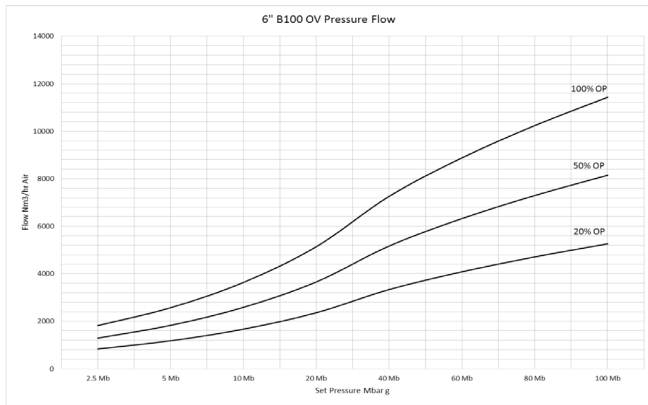

B100 Series OV

Pressure & Vacuum Relief Valves

