

→ Series 851

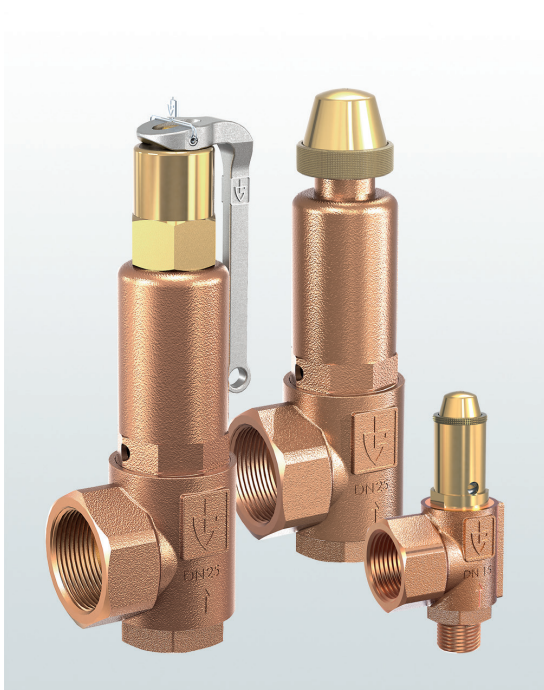

■ MATERIAL



■ SPECIFICATION



1/2" – 2"



– 60°C to + 225°C
depending on version



0,5 – 50 bar

■ SUITABLE FOR

Liquids	neutral and non-neutral	
Air, gases and vapours	neutral and non-neutral	
Steam		

■ EXAMPLES OF USE

For the protection of:

- Pressure-vessels/-systems for neutral / non-neutral vapours, gases and liquids
- Steam boilers and steam plants
- Stationary silos and bulk transport vehicles for liquid, granular and powdery goods

taking into account the plant-specific regulations and making use of the suitable valve versions and sealing materials.

- Mechanical engineering
- pump protection
- Apparatus construction and medical technology (sterilizers, autoclaves)
- shipbuilding and -repair
- Pressure booster systems water- / air-side
- Steam- and industrial-boiler systems

Safety valves are set and sealed at the factory.

■ APPROVALS

TÜV-Type test approval 666, 684	D/G, F, F/K/S ¹
EU type examination	S/G, L, F/K/S ¹
ASME	S, G, L
CRN	G
TSG ZF001-2006	D/G (S/G), F (L), F/K/S ¹
KGS	G
TR ZU 032/2013 - TR ZU 010/2011	D/G (S/G), F (L), F/K/S ¹
Requirements	
AD 2000 Data sheet A2	PED 2014/68/EU
TRD 421	ASME-Code Sec. VIII Div. 1
TRB 801 No. 22 and No. 23 ¹	KGS AA 319
DIN EN ISO 4126-1	

Classification society

DNV	DNV
Lloyd's Register EMEA	LR EMEA
American Bureau of Shipping	ABS
Bureau Veritas	BV
Russian Maritime Register of Shipping	RMS

■ MATERIALS

Component	Material	DIN EN	ASME
Inlet body	Gunmetal	CC499K	CC499K
Outlet body	Gunmetal	CC499K	CC499K
Internal parts	Brass	CW617N	CW617N
Spring	Stainless steel	1.4310	302
Bellows (optional)	Bronze	CW452K	C51900

¹only for versions with bellows

Series 851 ■ VALVE VERSION

s	non-gastight version of spring housing	for neutral media without counter pressure.
b	with bellows	for neutral and non-neutral media and/or counter pressure up to 4 bar. Spring, moving parts and the environment are protected from being affected by the medium.
t	gastight version of spring housing	for neutral and non-neutral media without counter pressure. The environment is protected from being affected by the medium. Only available without lifting device. This version is not available for inlet / outlet 15/15 and 20/20!
tb	gastight version with bellows	for neutral and non-neutral, flammable, toxic and environmentally hazardous media and/or counter pressure up to 4 bar. Spring, moving parts and the environment are protected from being affected by the medium. Without lifting device. Double gastight

■ MEDIUM

G	gaseous	Air, vapours, gases and - depending on safety valve version and seal - also for steam
F	liquid	The temperature of the medium under atmospheric pressure must not reach boiling point
GF	gaseous and liquid	Air, vapours, gases, steam and liquids -Not in combination with ASME Approval-

■ TYPE OF LIFTING MECHANISM

K	Standard with twist-type lifting mechanism
L	Lifting lever
O	without lifting device, standard for gastight versions

■ AVAILABLE NOMINAL DIAMETERS AND CONNECTION SIZES

Nominal diameter DN	15	20	25	32		
Inlet	1/2" (15)	3/4" (20)	1" (25)	1 1/4" (32)	1 1/2" (40)	2" (50)
Outlet	1/2" (15)	■				
	3/4" (20)		■*			
	1" (25)	■				
	1 1/4" (32)		■			
	1 1/2" (40)			■		
2" (50)				■	■	■

*20/20: from 20 bar upwards, only available as either „b“ or „tb“ version

■ TYPE OF CONNECTION INLET / OUTLET THREADED CONNECTIONS

f / f	Standard	Female thread BSP-P / Female thread BSP-P	DIN EN ISO 228-1 / DIN EN ISO 228-1
NPT-m/NPT-f		Male thread NPT / Female thread NPT	ANSI B 1.20.1
m / f		Male thread BSP-P / Female thread BSP-P	DIN EN ISO 228-1 / DIN EN ISO 228-1
BSP-Tm / f		Male thread BSP-T / Female thread BSP-P	DIN EN 10226, ISO 7-1 / DIN EN ISO 228-1

■ SEALS

NBR	Nitrile rubber	Elastomere moulded seal with metallic support up to 25 bar	-30°C to +130°C
EPDM	Ethylene propylene diene	Elastomere moulded seal with metallic support up to 25 bar	-40°C to +170°C
FKM	Fluorcarbon	Elastomere moulded seal with metallic support up to 25 bar	-20°C to +200°C
PTFE	Polytetrafluoroethylene	Flat seal up to 25 bar	-60°C to +225°C
PTFE+Kohle	Polytetrafluoroethylene + carbon	Flat seal from 25 bar	-60°C to +225°C
FFKM	Perfluorinated rubber	Elastomere moulded seal with metallic support up to 25 bar	-10°C to +225°C
MD	Metal-to-metal sealing	Flat seal	-60°C to +225°C

■ NOMINAL DIAMETERS, CONNECTIONS, INSTALLATION DIMENSIONS

Series 851: Connection, installation dimensions, ranges of adjustment											
Nominal diameter	DN	DN15			DN20		DN25	DN32			
Connection DIN EN ISO 228	G	1/2" (15)			3/4" (20)		1" (25)	1 1/4" (32)	1 1/2" (40)	2" (50)	
Outlet DIN EN ISO 228	G1	1/2" (15)	1" (25)	1" (25)	3/4" (20)	1 1/4" (32)	1 1/2" (40)	2" (50)	2" (50)	2" (50)	
Installation dimensions in mm	L	34	40	40	42	43	50	61	61	61	
	Lmax	65	65	65	91	91	92	92	92	92	
	H	79	77	131	137	138	178	241	241	241	
	H1	93	91	149	154	158	192	264	264	264	
	H2	79	77	131	138	139	175	241	241	241	
	Hmax	105	103	164	169	173	207	277	277	277	
	h	28	30	30	31	39	45	55	69	74	
	h1	15	15	15	16	16	18	20	23	25	
	SW1	30	30	30	36	36	46	55	55	70	
	SW2	-	40	40	32	50	58	70	70	70	
	Coefficients of flow ISO 4126-1	$c_w / K_{dr} (F)$	0,24	0,3 ¹	0,3 ¹	0,38	0,54	0,54	0,54	0,54	0,54
		$c_w / K_{dr} (D/G)^2$	0,33	0,33	0,33	0,52	0,6	0,56	0,56	0,56	0,56
	Coefficients of flow ASME-Code Sec. VIII Div. 1	$c_w / K_{dr} (F)$	-/-	3,046 ²	3,046 ²	-/-	0,492	0,492	0,492	0,492	0,492
		$c_w / K_{dr} (G)$	-/-	2,47 ²	2,47 ²	-/-	0,659	0,659	0,659	0,659	0,659
$c_w / K_{dr} (D)$		-/-	6,94 ²	6,94 ²	-/-	0,659	0,659	0,659	0,659	0,659	
Weight	kg	15,8	15,8	15,8	15,8	18	23	30,3	30,3	30,3	
Range of adjustment	bar	0,5-25	0,5-25	25,1-50	0,5-50	0,5-50	0,5-50	0,5-50	0,5-50	0,5-50	
Range of adjustment ASME	psi	-	15-363	363-725	-	15-725	15-725	15-725	15-725	15-725	

¹ Flow coefficients for blow-off pressures > 3,5 bar. Flow coefficients with bellows is 0,24.

² Rated slope value for G in scfm/psia; for D in pph/psia; for F in gpm/root (psid) psid = differential pressure before and after the valve

■ MAIN DIMENSIONS, INSTALLATION DIMENSIONS

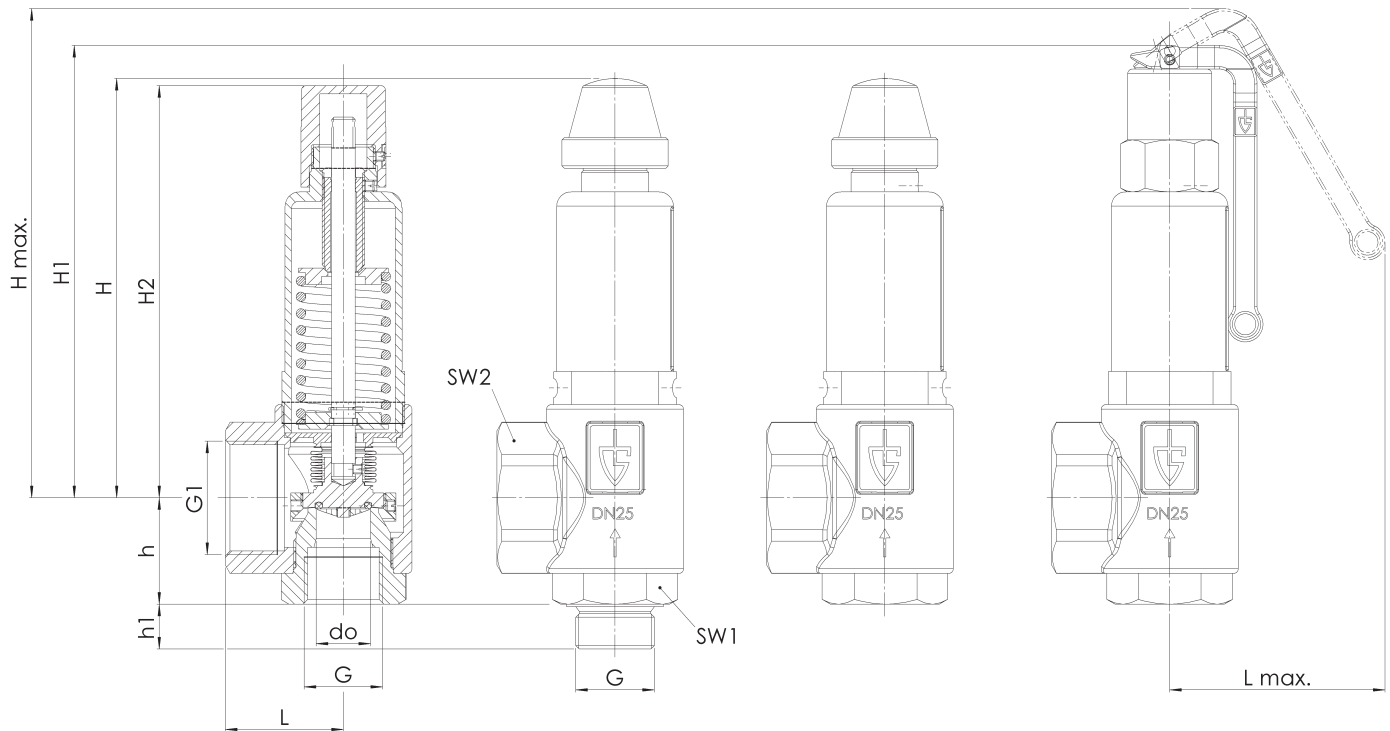

Series	Valve version	Medium	Lifting device	Nominal diameter DN	Connection type		Connection size		Seal	Options	Set pressure	Quantity
					Inlet	Outlet	Inlet	Outlet				
851	tb	GF	0	25	m	f	25	40	FKM		16,0	5
851												
851												
851												

■ TECHNICAL FINISHES, VARIANTS, ACCESSORIES

S18	Inlet area in hygienic finish by means of a flat seal (despite of an o-ring fixed by a nut)	<input type="checkbox"/>
S60	Pressure sensor connection M5 or G1/4 for monitoring the springhousing (only for valves with bellow)	<input type="checkbox"/>
S62	Inductive proximity sensor, fitted, for indication of valve position, including connection cable 5m	<input type="checkbox"/>

■ PROPERTIES

GOX	Especially for gaseous O2 applications by employment of specific materials including oil- and grease free production process	<input type="checkbox"/>	P03	Galvanically nickel-plated finish	<input type="checkbox"/>
P01	Oil- and grease-free production	<input type="checkbox"/>	P04	Chrome-plated finish	<input type="checkbox"/>
P02	Chemically nickel-plated finish	<input type="checkbox"/>			<input type="checkbox"/>

■ CERTIFICATES / APPROVALS

C01	Factory certificate acc. DIN EN 10204 2.2 (WKZ 2.2)	<input type="checkbox"/>	C06	ATEX evaluation acc. to 2014/34/EU	<input type="checkbox"/>
C02	Test certificate acc. DIN EN 10204 3.1 (WPZ 3.1)	<input type="checkbox"/>	C07	SIL evaluation relating to IEC 61508-2	<input type="checkbox"/>
C03	Material test certificate acc. DIN EN 10204 3.1 (MPZ 3.1) (pressure retaining part)	<input type="checkbox"/>	C09	Seat tightness test with helium, leak detection method under vacuum incl. Factory Inspection Certificate 3.1 acc. to DIN EN 10204	<input type="checkbox"/>
C04	TÜV/DEKRA individual inspection acc. EN 10204 3.2 (TÜV/DEKRA-APZ)	<input type="checkbox"/>	C10	Certificate of oil- and grease free production	<input type="checkbox"/>
C05	Sealing material Manufacturer certification (FDA, USP 3, 3-A,...), Please indicate description of certificate: _____	<input type="checkbox"/>	C11	Certification of the production process especially for gaseous oxygen applications by employment of specific materials	<input type="checkbox"/>

■ ADMISSIONS / ACCREDITATIONS

AA1	EC Type examination acc. to Directive 2014/68/EU	<input type="checkbox"/>	AK1	Det Norske Veritas (DNV) type approval	<input type="checkbox"/>
AA2	TÜV component test acc. to VdTÜV specification sheet SV 100	<input type="checkbox"/>	AK2	Lloyd's Register (LR) type approval	<input type="checkbox"/>
AA3	Certification acc. to ASME Boiler and Pressure Vessel Code, Section VIII.Div 1 (ASME) ¹	<input type="checkbox"/>	AK3	American Bureau of Shipping (ABS) type approval	<input type="checkbox"/>
AA4	EAC - certificate/declaration with passport for the valve and laser marking of the valve	<input type="checkbox"/>	AK4	Bureau Veritas (BV) type approval	<input type="checkbox"/>
AA5	Manufacture License of Special Equipment People's Republic of China (ML)	<input type="checkbox"/>	AK5	Russian Maritime Register of Shipping (RMRS) type approval	<input type="checkbox"/>
AA6	Certification acc. to Korean Gas Safety Corporation (KGS) ^{2,3}	<input type="checkbox"/>	AK6	Registro Italiano Navale (RINA) type approval	<input type="checkbox"/>
AA7	Registration according to Canadian Registration Number (CRN) ⁴	<input type="checkbox"/>	AL	Individual inspection by notified body inspector – (body to be indicated): _____	<input type="checkbox"/>

¹ASME not for gases in combination with liquids | ²KGS only for gases | ³KGS from 10 bar and only in combination with ASME | ⁴CRN only in combination with ASME

■ ENQUIRY

Copy and send to: info@klinger.dk

Series 851: Blowing-off rates at 10% above set pressure											
Nominal diameter DN		15				20					
Set pressure bar		Bellows				do = 15,8			do = 18		
		I	II	III without	III with	I	II	III	I	II	III
Air I Nm³/h	0,5	56	42	2,3	1,9	64	48	2,9	127	96	5,4
	1	87	69	3,1	2,5	120	96	4,0	189	151	7,3
	1,5	113	90	3,8	3,1	166	132	4,9	252	200	9,0
	2	141	111	4,4	3,6	205	161	5,6	316	249	10,4
Steam II kg/h	2,5	165	129	5,0	4,0	250	196	6,3	383	300	11,6
	3	189	148	5,4	4,4	298	233	6,9	447	349	12,7
Water III m³/h	3,5	214	166	5,9	4,7	336	262	7,4	504	392	13,7
	4	238	184	6,3	5,0	375	291	8,0	561	435	14,7
	4,5	262	203	6,7	5,3	413	319	8,4	618	478	15,6
	5	286	221	7,0	5,6	451	348	8,9	675	521	16,4
	5,5	310	239	7,4	5,9	489	377	9,3	732	564	17,2
	6	335	257	7,7	6,2	527	406	9,7	790	608	18,0
	6,5	359	275	8,0	6,4	565	434	10,1	847	650	18,7
	7	383	293	8,3	6,6	604	462	10,5	904	692	19,4
	7,5	407	311	8,6	6,9	642	491	10,9	961	735	20,1
	8	431	329	8,9	7,1	680	519	11,3	1018	777	20,8
	8,5	456	347	9,2	7,3	718	547	11,6	1075	820	21,4
	9	480	365	9,4	7,5	756	576	11,9	1132	862	22,0
	9,5	504	383	9,7	7,7	794	604	12,3	1190	905	22,6
	10	528	401	9,9	7,9	833	632	12,6	1247	947	23,2
	11	577	437	10,4	8,3	909	688	13,2	1361	1031	24,3
	12	625	472	10,9	8,7	985	744	13,8	1475	1115	25,4
	13	674	508	11,3	9,1	1061	801	14,3	1590	1199	26,5
	14	722	544	11,8	9,4	1138	857	14,9	1704	1284	27,5
	15	770	580	12,2	9,7	1214	914	15,4	1818	1368	28,4
	16	819	616	12,6	10,1	1290	970	15,9	1932	1453	29,4
17	867	650	13,0	10,4	1367	1025	16,4	2047	1535	30,3	
18	916	686	13,3	10,7	1443	1081	16,9	2161	1619	31,1	
19	964	721	13,7	11,0	1519	1137	17,3	2275	1703	32,0	
20	1013	757	14,0	11,2	1596	1193	17,8	2390	1787	32,8	
21	1061	793	14,4	11,5	1672	1250	18,2	2504	1872	33,6	
22	1109	829	14,7	11,8	1748	1306	18,7	2618	1956	34,4	
23	1158	865	15,1	12,1	1825	1363	19,1	2732	2040	35,2	
24	1206	900	15,4	12,3	1901	1419	19,5	2847	2125	35,9	
25	1255	936	15,7	12,6	1977	1475	19,9	2961	2209	36,7	
26	1303	-	16,0	12,8	2054	-	20,3	3075	-	37,4	
27	1352	-	16,3	13,1	2130	-	20,7	3190	-	38,1	
28	1400	-	16,6	13,3	2206	-	21,1	3304	-	38,8	
29	1449	-	16,9	13,5	2283	-	21,4	3418	-	39,5	
30	1497	-	17,2	13,8	2359	-	21,8	3532	-	40,2	
32	1594	-	17,8	14,2	2511	-	22,5	3761	-	41,5	
34	1691	-	18,3	14,7	2664	-	23,2	3990	-	42,8	
36	1788	-	18,8	15,1	2817	-	23,9	4218	-	44,0	
38	1884	-	19,4	15,5	2969	-	24,5	4447	-	45,2	
40	1981	-	19,9	15,9	3122	-	25,2	4675	-	46,4	
42	2078	-	20,4	16,3	3275	-	25,8	4904	-	47,6	
44	2175	-	20,8	16,7	3427	-	26,4	5132	-	48,7	
46	2272	-	21,3	17,0	3580	-	27,0	5361	-	49,8	
48	2369	-	21,8	17,4	3732	-	27,6	5589	-	50,8	
50	2466	-	22,2	17,8	3885	-	28,1	5818	-	51,9	

*) only possible with metal-to-metal sealing

**) Version with bellows only available from 1 bar

CONTINUATION - Series 851: Blowing-off rates at 10% above set pressure

Nominal diameter DN		25			32			
		I	II	III	I	II	III	
Set pressure bar								
Air I	0,5	199	150	8,8	353	266	15,4	
	1	291	232	12,0	515	411	20,8	
	1,5	390	309	14,7	683	542	25,5	
	Nm ³ /h	2	489	385	16,9	832	656	29,4
		2,5	583	457	18,9	1012	793	32,9
Steam II	3	681	532	20,8	1182	924	36,0	
	kg/h	3,5	768	597	22,4	1333	1036	38,9
Water III	4	855	663	24,0	1484	1151	41,6	
	m ³ /h	4,5	942	729	25,4	1635	1265	44,1
	5	1029	794	26,8	1786	1378	46,5	
	5,5	1116	860	28,1	1937	1492	48,8	
	6	1203	926	29,3	2088	1607	50,9	
	6,5	1290	990	30,5	2239	1719	53,0	
	7	1377	1054	31,7	2390	1830	55,0	
	7,5	1464	1119	32,8	2542	1943	56,9	
	8	1552	1184	33,9	2693	2056	58,8	
	8,5	1639	1249	34,9	2844	2168	60,6	
	9	1726	1314	35,9	2995	2281	62,4	
	9,5	1813	1379	36,9	3146	2392	64,1	
	10	1900	1443	37,9	3297	2504	65,8	
	11	2074	1571	39,7	3599	2727	69,0	
	12	2248	1699	41,5	3902	2948	72,0	
	13	2422	1827	43,2	4204	3172	75,0	
	14	2596	1957	44,8	4506	3396	77,8	
	15	2771	2085	46,4	4808	3618	80,5	
	16	2945	2214	47,9	5111	3842	83,2	
	17	3119	2339	49,4	5413	4059	85,7	
	18	3293	2467	50,8	5715	4281	88,2	
	19	3467	2594	52,2	6017	4503	90,6	
	20	3641	2723	53,6	6320	4726	93,0	
	21	3816	2852	54,9	6622	4950	95,3	
	22	3990	2981	56,2	6924	5173	97,5	
	23	4164	3109	57,5	7226	5396	99,7	
	24	4338	3238	58,7	7529	5619	101,9	
	25	4512	3366	59,9	7831	5842	104,0	
	26	4686	-	61,1	8133	-	106,0	
	27	4860	-	62,3	8435	-	108,0	
	28	5035	-	63,4	8738	-	110,0	
	29	5209	-	64,5	9040	-	112,0	
	30	5383	-	65,6	9342	-	113,9	
	32	5731	-	67,8	9947	-	117,6	
	34	6080	-	69,9	10551	-	121,2	
	36	6428	-	71,9	11156	-	124,8	
	38	6776	-	73,9	11760	-	128,2	
	40	7124	-	75,8	12365	-	131,5	
	42	7473	-	77,6	12969	-	134,8	
	44	7821	-	79,5	13574	-	137,9	
	46	8169	-	81,3	14178	-	141,0	
	48	8518	-	83,0	14783	-	144,1	
	50	8866	-	84,7	15387	-	147,0	

Series 851: Blowing-off rates at 10% above set pressure													
Nominal diameter DN		15			20			25			32		
		d0 = 0,622 inch (15,8 mm)			d0 = 0,709 inch (18 mm)			d0 = 0,906 inch (23 mm)			d0 = 1,193 inch (30,3 mm)		
Set pressure psi(g)		I	II	III	I	II	III	I	II	III	I	II	III
Air I	15	80,8	226,9	12,9	155,9	437,7	31,2	254,5	714,7	51,0	441,8	1240,4	88,5
	30	117,9	331,0	17,5	227,4	638,5	42,3	371,3	1042,5	69,1	644,4	1809,3	119,9
	40	145,1	407,4	20,2	279,9	785,8	48,8	456,9	1282,9	79,8	793,0	2226,6	138,4
Steam II	50	172,3	483,7	22,6	332,3	933,0	54,6	542,6	1523,4	89,2	941,6	2643,8	154,8
	60	199,5	560,1	24,7	384,7	1080,3	59,8	628,2	1763,8	97,7	1090,2	3061,1	169,5
	70	226,7	636,4	26,7	437,2	1227,5	64,6	713,8	2004,2	105,5	1238,8	3478,3	183,1
Water III	87	253,9	712,7	28,6	489,6	1374,8	69,1	799,4	2244,6	112,8	1387,4	3895,6	195,8
	90	281,1	789,1	30,3	542,1	1522,0	73,3	885,1	2485,0	119,6	1536,1	4312,8	207,6
	100	308,3	865,4	31,9	594,5	1669,3	77,2	970,7	2725,4	126,1	1684,7	4730,1	218,9
GPM	110	335,5	941,8	33,5	647,0	1816,5	81,0	1056,3	2965,9	132,3	1833,3	5147,3	229,5
	120	362,6	1018,1	35,0	699,4	1963,8	84,6	1141,9	3206,3	138,1	1981,9	5564,6	239,7
	130	389,8	1094,4	36,4	751,9	2111,0	88,1	1227,6	3446,7	143,8	2130,5	5981,8	249,5
	140	417,0	1170,8	37,8	804,3	2258,3	91,4	1313,2	3687,1	149,2	2279,1	6399,0	259,0
	150	444,2	1247,1	39,1	856,7	2405,5	94,6	1398,8	3927,5	154,4	2427,7	6816,3	268,0
	160	471,4	1323,5	40,4	909,2	2552,8	97,7	1484,5	4167,9	159,5	2576,3	7233,5	276,8
	170	498,6	1399,8	41,7	961,6	2700,0	100,7	1570,1	4408,4	164,4	2724,9	7650,8	285,4
	180	525,8	1476,1	42,9	1014,1	2847,3	103,6	1655,7	4648,8	169,2	2873,5	8068,0	293,6
	190	553,0	1552,5	44,0	1066,5	2994,5	106,5	1741,3	4889,2	173,8	3022,1	8485,3	301,7
	200	580,2	1628,8	45,2	1119,0	3141,8	109,2	1827,0	5129,6	178,3	3170,7	8902,5	309,5
	210	607,4	1705,2	46,3	1171,4	3289,0	111,9	1912,6	5370,0	182,7	3319,3	9319,8	317,2
	220	634,6	1781,5	47,4	1223,9	3436,3	114,6	1998,2	5610,4	187,0	3467,9	9737,0	324,6
	230	661,8	1857,8	48,4	1276,3	3583,5	117,1	2083,8	5850,9	191,2	3616,5	10154,3	331,9
	240	688,9	1934,2	49,5	1328,7	3730,8	119,7	2169,5	6091,3	195,4	3765,1	10571,5	339,1
	250	716,1	2010,5	50,5	1381,2	3878,0	122,1	2255,1	6331,7	199,4	3913,8	10988,8	346,0
	260	743,3	2086,9	51,5	1433,6	4025,3	124,5	2340,7	6572,1	203,3	4062,4	11406,0	352,9
	270	770,5	2163,2	52,5	1486,1	4172,5	126,9	2426,3	6812,5	207,2	4211,0	11823,3	359,6
	280	797,7	2239,5	53,5	1538,5	4319,8	129,2	2512,0	7052,9	211,0	4359,6	12240,5	366,2
	290	824,9	2315,9	54,4	1591,0	4467,0	131,5	2597,6	7293,3	214,8	4508,2	12657,8	372,7
	300	852,1	2392,2	55,3	1643,4	4614,3	133,8	2683,2	7533,8	218,4	4656,8	13075,0	379,1
	320	906,5	2544,9	57,1	1748,3	4908,8	138,2	2854,5	8014,6	225,6	4954,0	13909,5	391,5
	340	960,9	2697,6	58,9	1853,2	5203,2	142,4	3025,7	8495,4	232,5	5251,2	14744,0	403,6
	360	1015,3		60,6	1958,1		146,5	3197,0		239,3	5548,4		415,3
	380	1069,6		62,3	2063,0		150,6	3368,2		245,8	5845,6		426,6
	400	1124,0		63,9	2167,9		154,5	3539,5		252,2	6142,8		437,7
	420	1178,4		65,5	2272,7		158,3	3710,7		258,4	6440,1		448,5
	440	1232,8		67,0	2377,6		162,0	3882,0		264,5	6737,3		459,1
	460	1287,2		68,5	2482,5		165,7	4053,2		270,5	7034,5		469,4
	480	1341,6		70,0	2587,4		169,2	4224,5		276,3	7331,7		479,5
	500	1395,9		71,4	2692,3		172,7	4395,8		282,0	7628,9		489,4
	550	1531,9		74,9	2954,5		181,1	4823,9		295,7	8371,9		513,3
	600	1667,9		78,3	3216,7		189,2	5252,0		308,9	9115,0		536,1
	650	1803,8		81,4	3479,0		196,9	5680,1		321,5	9858,0		558,0
	700	1939,8		84,5	3741,2		204,3	6108,3		333,6	10601,0		579,0
	750	2075,7		87,5	4003,4		211,5	6536,4		345,4	11344,1		599,4
	800	2211,7		90,4	4265,6		218,5	6964,5		356,7	12087,1		619,0
	850	2347,7		93,1	4527,8		225,2	7392,7		367,7	12830,1		638,1
	900	2483,6		95,8	4790,1		231,7	7820,8		378,3	13573,2		656,6
	950	2619,6		98,5	5052,3		238,1	8248,9		388,7	14316,2		674,6
	1015	2796,3		101,8	5393,2		246,1	8805,5		401,8	15282,1		697,3